

Concrete Pipe News



SPRING 2015
Volume 67 No. 2



American **Concrete Pipe** Association
concrete-pipe.org

Concrete Pipe News is published four times each year by the American Concrete Pipe Association. It is available in hard copy and digital format posted on the ACPA website. *Concrete Pipe News* content is linked to archived technical information, research and product development, educational products and applications of precast concrete pipe and boxes. Content is linked to archived word and graphic files on the ACPA and other industry-wide websites. Readers include engineers, specifiers, contractors, suppliers, government officials, and members of the American Concrete Pipe Association.

Media Task Group

Mark Omelaniec, Chair
The Langley Concrete Group of Companies

Scott Lander
Hamilton Kent

Richard Langguth
Cretex Concrete Products Midwest, Inc.

Ed Sexe
Cretex Concrete Products Midwest, Inc.

Marketing Committee Chair
Randy Wahlen
Oldcastle Precast, Inc.

Contract Editorial Service
A. Grant Lee
AGL Marketing Limited

ACPA Editorial Staff
Sheila Clevenger

Published by:

American Concrete Pipe Association

Phone: (972) 506-7216

E-mail: info@concrete-pipe.org
concrete-pipe.org

On the Cover:

Reconstruction required 57,000 feet of reinforced concrete pipe storm sewer.



American Concrete Pipe Association

Opinions expressed by authors other than staff of the American Concrete Pipe Association do not necessarily reflect the official positions or policies of the Association. No part of this publication may be reproduced or transmitted by any means without written permission from the publisher.

©2015 American Concrete Pipe Association, all rights reserved.

Editorial

Possible Effects of Water Conservation on Concrete Pipeline System Design



Matt Childs, P.E., President
American Concrete Pipe Association

resistance of systems to corrosion, introduced by pipeline environments that are favorable to the essentials for producing corrosive elements. Concrete pipe designed for a decades-old system, may not now be the ultimate design for a lower-flow pipeline system. Considering that low impact development devices (LID) and sustainable drainage systems (SuDS) are being specified to reduce runoff into storm sewers, a redesign of traditional sanitary and storm sewer pipeline systems may not be too far away.

Installation of high-efficiency toilets, urinals, showerheads, faucets, clothes washers, dishwashers, and other water-saving devices and conservation practices at home and at work are not an option—they are a necessity in many states. This water-saving technology, combined with modern pipeline system designs using LIDS and SuDS can be expected to impact Standards and specifications for pipeline and culvert products.

The challenge for designing and constructing resilient sanitary and storm sewers may not be with water-saving devices in the home and workplace, and water conservation policies set by governments. The challenges may lie with the design of antiquated sewer pipeline systems, which are gravity fed and using more water than needed to transport waste. Solutions may lie in the design of sanitary sewers that can accommodate lower flows while controlling the internal environment using new technology and pipeline system design. Pipeline systems would have to be modernized in their design before being replaced.

Considering extremes in rainfall in certain regions of the country, specification of the more traditional storm sewers may be an option. Large diameter storm sewer systems that include inline or appended detention and retention structures are proven to be effective in mitigating the risks associated with floods. When combined with products for SuDS and LIDS, storm sewer systems can contribute to aquifer recharge while improving the quality of runoff.

Modern sanitary pipeline systems may require redesigns and downsizing in some regions, and storm sewers and culverts may require upsizing in others. Tightly-sealed sanitary sewers and decentralized treatment facilities may be part of modern pipeline systems to control flows and internal pipeline environments. In a similar way that solid waste is reduced, recycled and reused, people may need to learn new ways of dealing with what waste is placed into sanitary sewer systems from the home, and how sanitary waste is disposed.

This century can expect to see technology changing the way sanitary and storm sewer pipeline systems are designed. The concrete pipe industry has anticipated this change and has the products and materials to help effect change in modern pipeline systems design.

LINKS

1. epa.gov/greeningepa/water

By 2013, the U.S. population had doubled in 50 years. At least 36 states were facing [water shortages](#)¹ while the need for water had tripled. Currently, two generations of Americans are practicing and advocating water conservation in the face of significantly increased demand, rapidly changing weather patterns, and the signs of changing climate regimes. When less water is being consumed due to water conservation practices, less waste water is being discharged into sewers. Sanitary and storm sewer pipeline systems and wastewater treatment plants are affected.

Unless specially designed for low flows, sanitary sewers rely on predetermined volumes of water and grade to transport solids to wastewater treatment facilities. When flows are reduced in older sanitary pipeline systems, the performance of the system may be compromised because the parameters of the original hydraulic design have changed. Concrete mixes and pipeline grade have an impact on the

Largest Transportation Project in WI History Goes with Concrete Pipe

By Paul Lohmiller, P.E.

Executive Director, Wisconsin Concrete Pipe Association
paul.wcpa@charter.net

The [Zoo Interchange](#)¹ in Milwaukee is a freeway Interchange on the west side of the city, southeast of the 200 acre Milwaukee County Zoo. It was built in 1963, as one of the first Interstate Highway projects in Wisconsin. Forming the junction of I-94, I-894, and US 45, it is the busiest interchange in the state. Deteriorated structures of the interchange, obsolete design of the roadway and bridges, current and future capacity needs, and high crash rates, prompted the [Wisconsin Department of Transportation \(WisDOT\)](#)² to redesign and reconstruct the interchange to increase efficiency, reduce accidents and add capacity. Reconstruction of the interchange required 57,000 feet (over 10 miles) of reinforced concrete pipe storm sewer.

The first three years of the project was focused on upgrading the arterial streets to handle additional traffic generated by closures on the interstate when work began on the Interchange itself in late 2014. In addition to the new storm sewers, the project included contracts for 21 bridges, 30 walls, 11 noise barriers, concrete pavement, 20 million lbs of structural steel, steel tub flyover bridges with stainless steel concrete deck reinforcement, pre-stressed concrete girder bridges, earthwork, structure and pavement demolition, intelligent transportation systems, large diameter drilled shafts, MSE walls with precast panels, utility relocations and pile supported foundations. The current project is valued at nearly \$200 m.

The main challenge faced by contractors was the aggressive schedule, combined with the uncertainty of harsh weather conditions. WisDOT scheduled completion of the Interchange structures before December 2015. The Phase 1 core contract running through June, 2016 requires the Blue Mound Road Bridge over Highway 45 to be demolished and rebuilt before Memorial Day 2015. A massive new pumping station must be installed by the end of May 2015, and a 60-inch storm sewer must be tunneled underneath the interchange.

[County Materials Corporation](#)³ supplied a wide range of reinforced concrete pipe ranging in size from 12-inch to 96-inch diameter in Classes III to V. In addition, there was over 2,000 feet of Class HE III 38-inch x 60-inch, 58-inch x 91-inch and 77-inch x 121-inch horizontal elliptical pipe along with nearly 1000 structures including inlets, catch basins and manholes ranging in diameter from 3-foot to 12-foot. County Materials shipped the concrete pipe and structures from the company's various locations throughout Wisconsin.

The Zoo Interchange is a major transportation link in Wisconsin, and a significant component of America's Interstate Highway network. The core materials for the interchange are concrete and steel. It is designed to be a [resilient asset](#)⁴ for the city and state for generations. Large quantities of reinforced concrete storm sewer pipelines and culverts are critical infrastructure that will function as long as the design life of the intersection. The ability for designers to specify different classes of standard engineered pipe with varying strengths and shapes to save costs of installation, while accommodating earth and live loads of traffic, suggests that WisDOT has strong specification guidelines and rules that support good engineering practices.

LINKS

1. roadwaystandards.dot.wi.gov/hcci/projects/se.htm
2. dot.state.wi.us
3. countymaterials.com
4. concrete-pipe.org/magazine/2014springcpnews.html (editorial)

Contractors:
Wisconsin Constructors II, LLC
• Lunda Construction Co.
• Edgerton Contractors, Inc.
• Michaels Corporation
Super Excavators, Menomonee Falls, WI

Learn More About Buried Infrastructure

- **Keyword Search on American Concrete Pipe Association Website** (storm, interchange, MAP 2, resilient, sustainable, bridge, precast) concrete-pipe.org
- **Concrete Pipe Design Manual** concrete-pipe.org/pages/design-manual.html
- **Concrete Pipe News** concrete-pipe.org/pages/cpnews.html

Photos: Paul Lohmiller Wisconsin Concrete Pipe Association



RCP sizes ranged from 12-inch to 96-inch diameter with strengths of Class III, IV and V.



Concrete pipe and other precast concrete products delivered according to tight construction schedule.



Over 10 miles of RCP, manholes, catch basins and inlets supplied to fit tight construction schedule.



Using precast allowed the contractor to demolish the existing structure while installing the boxes.



110-year-old brick storm sewer replaced with, 8-foot x 12-foot precast concrete box storm sewer.



Phases 1 and 2 specified 3,048 feet of wetcast and drycast precast concrete boxes.

Aged Masonry Storm Sewer Replaced With Precast Concrete Box System

By Nathan Kampman, P.E.
Sales Manager, Cretex Concrete Products
nkampman@cretex.com

A portion of an [arched brick storm sewer](#)¹ structure, eight feet tall and 14 feet wide in Cedar Rapids, Iowa, built in the late 1800s and early 1900s collapsed in 2009 from damage caused by the floods of 2008. Known as the “Vinton Ditch,” the storm sewer is a major structure that drains a large area of the City discharging to the Cedar River. The collapse damaged a section of E Avenue that resulted in a block of the roadway limited to one lane of traffic. The 110-year-old brick storm sewer was replaced with a rectangular concrete box culvert, 8 feet high and 12 feet wide. Federal Community Development Block Grant disaster funds paid the cost of the \$8.9-million permanent replacement project, which included the new storm sewer, street reconstruction and sidewalk replacement.

Precast concrete boxes were specified for the project for two significant reasons. The tight installation corridor required the contractor to keep the excavation trench as narrow as possible for the installation. The trench width would have needed to be wider if the structure was poured-in-place or if another shape of the drainage structure were specified. A wider trench would have also made significant shoring necessary to stabilize building foundations through a portion of the installation corridor. In addition, the contractor was required to keep the storm sewer operational during construction since the “ditch” drains a large area of the city and any storm drainage would be able to flow from the existing line into the new line in the event of storms during construction. Using precast allowed the contractor to demolish the existing structure while installing the boxes. [Cretex Concrete Products](#)² had a field representative onsite frequently to provide service and guidance. This allowed any questions to be quickly addressed during the installation.

The precast box sections were produced by wetcast and drycast production methods at the Cretex facilities in Des Moines and Iowa Falls, Iowa. There were several bend sections on the project and accuracy was extremely important to connect with the hard tie in points on either end of the project. The boxes were produced according to [ASTM C1577](#)³, Standard Specification for Precast Reinforced Concrete Monolithic Box Sections for Culverts, Storm Drains, and Sewers Designed According to AASHTO LRFD. Additional reinforcing was provided in the top slab to accommodate the contractor’s method of handling and installing the boxes.

The Phase 1 project (1,426 feet) was constructed by Rathje Construction of Marion, Iowa and Phase 2 (1,622 feet) was constructed by Zinser Grading & Excavating of Walford, Iowa. Foth Infrastructure & Environment, LLC was the design consultant.

LINKS

- [1. kcrj.com/news/local/Replacement-Of-110-Year-Old-Brick-Storm-Sewer-Set-To-Start-This-Summer-143428216.html](http://kcrj.com/news/local/Replacement-Of-110-Year-Old-Brick-Storm-Sewer-Set-To-Start-This-Summer-143428216.html)
- [2. cretexconcreteproducts.com](http://cretexconcreteproducts.com)
- [3. astm.org/Standards/C1577.htm](http://astm.org/Standards/C1577.htm)

Learn More About Buried infrastructure

- **Keyword Search on American Concrete Pipe Association Website** (culvert, storm, drain, box, sewer, flood) concrete-pipe.org
- **Concrete Pipe Design Manual** concrete-pipe.org/pages/design-manual.html
- **Concrete Pipe News** concrete-pipe.org/pages/cpnews.html

Dry Cast and Jointing - Special Considerations for BNSF Box Culverts

By Eric Chiasson, Northwest Area Manager - Construction
Denver Transit Partners
EricChiasson@dtjv.com / EricChiasson@amesco.com
Brian Schram, P.E., Region Engineer
Rinker Materials - Concrete Pipe Division, CEMEX
briank.schram@cemex.com

Colorado's Regional Transportation District's (RTD) Northwest Corridor commuter rail expansion into [Westminster](#)¹, north of Denver includes a station west of Federal Blvd. which has two large drainage systems comprised of a double 8-foot x 8-foot box culvert and a single 8-foot x 4-foot box culvert. These box culverts were specified for installation under the existing BNSF tracks and the new proposed commuter rail tracks next to them. [Denver Transit Partners \(DTP\)](#)² is the project's joint venture building the commuter rail expansion, and [Rinker Materials - Concrete Pipe Division](#)³ is the main supplier of precast products.

[Dry-cast precast](#)⁴ was chosen for the culverts, although the BNSF's specifications were not conducive to the use of the standard dry-cast production method accepted by state DOTs. Until this project, BNSF preferred only wet-cast boxes and had them shipped from select few locations across the country.

BNSF's engineering group, Rinker Materials, and Ames Construction (the civil construction arm of DTP) collaborated to update and modify BNSF's precast specifications to include the dry-cast method for precast production, in addition to the wet-cast method. Eric Chiasson (Ames Construction) and Brian Schram (Rinker Materials) contributed significantly to this shift in the BNSF specifications. The Westminster Station drainage project was one of the first in the country to benefit from dry-cast boxes under BNSF tracks. Changing to the dry-cast method will significantly reduce BNSF's capital cost for constructing box culverts, since dry-casters are located in most states. The dry-cast method moves the BNSF specifications to a more standard way of construction, and provides the contractor more flexibility in constructing the culverts.

Due to the significantly higher loads from freight rail traffic, precast boxes for a railroad culvert require a more robust design than precast boxes for a regular DOT culvert. The box walls are thicker, reinforcing is a lot heavier and the connections between the box sections are unique. Where conventional precast box sections have joint sealant material, box sections for railroads are connected by steel bolts mechanically fastened to both sides of the joint - on top and on the sides.

BNSF scheduled a track outage near Westminster Station for the neighboring Clear Creek Bridge Replacement project (Ames Construction under separate BNSF contract). This action allowed installation of the double 8-foot x 8-foot box culvert (two barrels 115 feet long) in two days during the same track outage for completion of construction in a single phase. Once the boxes were installed and backfilled, the tracks were reconnected and ready for traffic.

The single 8-foot x 4-foot box culvert (110 feet long) was not included in the operation due to strict scheduling of track outages by BNSF. A second installation during this window would have placed the schedule for the outage at risk and could have affected railroad traffic several states away if not managed properly. The smaller culvert was scheduled for construction in April, 2015.

Future specifications for concrete box culverts of BNSF projects are expected to contain the dry-cast method of production. Standard designs will be proposed in some applications.

LINKS

1. rtd-fastracks.com/nw_77
2. denvertransitpartners.com
3. rinkerpipe.com
4. rinkerpipe.com/TechnicalInfo/InfoBriefs.aspx

Learn More About Buried Infrastructure

- **Keyword Search on American Concrete Pipe Association Website** (rail, box, culvert, load, dry, wet, Denver, storm) concrete-pipe.org
- **Concrete Pipe Design Manual** concrete-pipe.org/pages/design-manual.html
- **Concrete Pipe News** concrete-pipe.org/pages/cpnews.html

Photos: Courtesy of Eric Chiasson, Northwest Area Manager – Construction Denver Transit Partners



Double 8-foot x 8-foot culvert under the BNSF tracks.



Galvanized exterior steel connection between each box section.

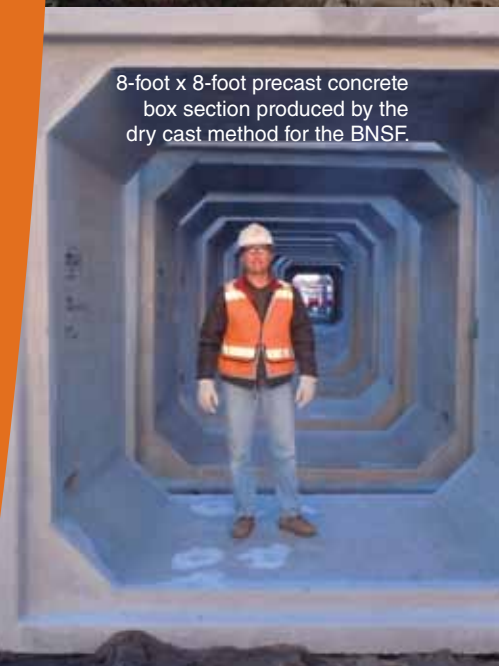

8-foot x 8-foot precast concrete box section produced by the dry cast method for the BNSF.

Precast Concrete Boxes With V-Channel a Philadelphia First

By Michale Snipas, Sales Representative
Oldcastle Precast
Michael.Snipas@oldcastle.com

Specification of 11-foot x 11-foot precast concrete boxes with a V-shaped channel for an outfall structure that replaced an existing 16-foot diameter brick combined sewer outfall located approximately 100 to 150 yards from the Delaware River was a first for the City of Philadelphia. The project is part of a U.S. EPA Order to reduce the number of CSO discharges to the Delaware River. The [purpose](#)¹ of the \$12.5 million project was to modify the existing Laurel Street outfall to reduce the risk of basement flooding and raw wastewater backflows within the Northern Liberties and Fishtown neighborhoods. As part of its original development plan and \$164 million expansion of the [SugarHouse Casino](#)², SugarHouse agreed to upgrade and widen the Laurel Street CSO. The combined sewer had served the city for more than 100 years. In addition to the new outfall, the project replaced a 66-foot deteriorated timber and rock crib bulkhead with a concrete structure that accommodates the precast outfall.

Historically, Philadelphia insisted on cast-in-place (CIP) concrete culverts for all of their construction projects because specifiers believed that CIP provided a huge advantage over precast systems considering water tightness of the structure. Oldcastle was able to prove to the owner, the engineer and the Philadelphia Water Department that a precast culvert would be a viable option for performance and accelerate a very aggressive construction schedule. It was imperative to restore the operation of the Laurel Street CSO as soon as possible.

The design of the 436-foot culvert presented many challenges to the engineering department of Oldcastle's Telford PA facility. It was paramount for [Oldcastle Precast](#)³ to provide precast concrete boxes that met the Philadelphia Water Department's stringent design criteria for underground structures. There were load considerations to be worked into the culvert design since the precast structure would be situated beneath the main parking lot for the casino, a small building called the SugarHouse Poker Room and an access road that would connect the main parking lots to additional parking areas. The connector road would serve as the main access road for bus and delivery truck traffic to and from the casino.

Oldcastle's design of the precast boxes with V-shaped channel was reviewed and approved by Urban Engineers of Philadelphia allowing the box design to go into production. Manufacturing of the culvert sections took approximately four months with time to spare for the project to be completed on schedule.

Photos: Courtesy of Oldcastle Precast

LINKS

1. nap.usace.army.mil/Portals/39/docs/regulatory/publicnotices/Public%20Notice%202013-0557-24.pdf
2. articles.philly.com/2013-10-26/news/43397590_1_sugarhouse-casino-expansion-first-casino
3. oldcastleprecast.com/Pages/default.aspx

Learn More About Buried Infrastructure

- **Keyword Search on American Concrete Pipe Association Website** (culvert, box, precast, channel, outfall, CSO, combined) concrete-pipe.org
- **Concrete Pipe Design Manual** concrete-pipe.org/pages/design-manual.html
- **Concrete Pipe News** concrete-pipe.org/pages/cpnews.html



The first 3 sections set that help make up the bulk head. The brick out fall that was being replaced is seen in the background. Also shown, the entire structure was set on piles with a cast-in-place cap.

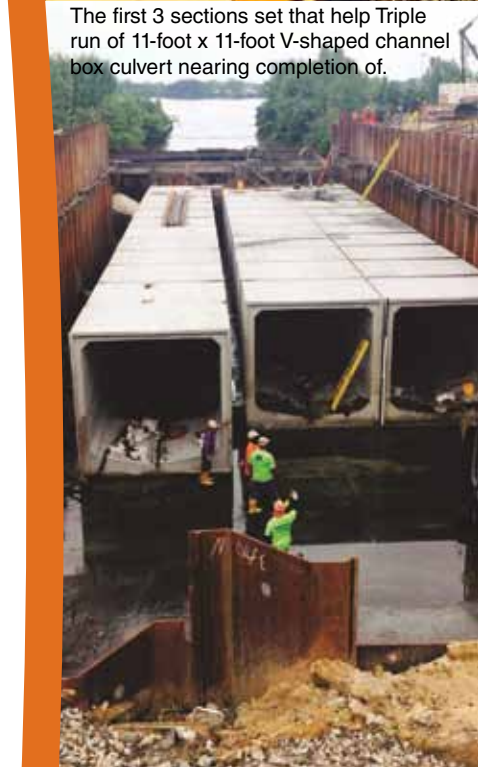

The first 3 sections set that help Triple run of 11-foot x 11-foot V-shaped channel box culvert nearing completion of.



11-foot x 11-foot V-shaped channel box culvert being set on cast-in-place pile cap.

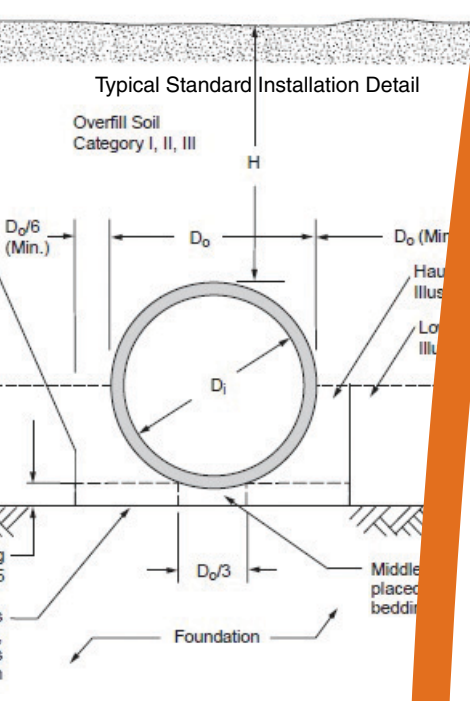

Project Costs Can Be Reduced by Assessing Both Pipe and Bedding

By Andrew Cortese, P.Eng., Technical Marketing & Operations Engineer
 Ocean Pipe
 ACortese@oceanpipe.com

Approximately 140m of 1800mm diameter reinforced concrete pipe (RCP) was designed to accommodate the weight of 13.5m of earth cover and the load from a bridge footing on the Powell Street [Overpass project](#)¹ in Vancouver, British Columbia. The original design assumed a Type 1 [Standard Installation](#)² with a specific Direct Design for the concrete pipe, but this was changed to a Type 2 Standard Installation that, despite requiring a more expensive Direct Design concrete pipe, decreased the overall installed cost of the project.

ASTM C76, the Standard Specification for Reinforced Concrete Culvert, Storm Drain, and Sewer Pipe, was thought to be incapable of handling the massive anticipated earth or surcharge load on the 1800mm pipe, therefore, engineers at [Ocean Pipe](#)³ created a custom pipe designed specifically for the expected loading conditions ([Direct Design](#)⁴) instead of the typical method of testing to a relateable D-load ([Indirect Design](#)⁵).

A Type 2 Standard Installation (ASTM C1479 – Standard Practice for Installation of Precast Concrete Sewer, Storm Drain, and Culvert Pipe Using Standard Installations) was accepted by [Pedre Contractors Ltd.](#)⁶ who was contracted to install the pipeline. The reason for accepting the Type 2 design was because it allowed the contractor to use locally available bedding material and required less compaction during backfilling. The cost of the pipe-soil system as a whole decreased with specially-designed RCP and a Type 2 installation. A Type 2 installation permits adequately compacted native silty granular soils or select granular soils to be used in the haunch and outer bedding zones. This is intended to allow the use of soil frequently found at a site.

As a designer, specifier, owner, or installer it is important to understand that the cost of the pipe-soil system includes more than just the cost of the pipe. The installation includes costs such as digging the trench, removing native material, joining the pipes, importing bedding material, backfilling the trench, compacting the embankment, and performing post-installation inspection testing. It is always good practice to choose an embedment type that will minimize the overall cost of a project. Standard Installations are based on a 1970s research program by the ACPA to determine the interaction of buried concrete pipe and soil. The research resulted in the comprehensive finite element computer program SPIDA (Soil-Pipe Interaction Design and Analysis) that was used to develop the four Types of Standard Installation.

The storm drain was part of the design of the Powell Street project in Vancouver, British Columbia; a \$50-million major road and rail infrastructure enhancement. The key goals of the project were to expand capacity and enhance the rail network that supports the movement of goods through Port Metro Vancouver, and improve access and safety for pedestrians, cyclists, and commuters.

LINKS

1. vancouver.ca/home-property-development/powell-street-overpass-project.aspx
2. concrete-pipe.org/pdf/standard-installation.pdf
3. oceanpipe.com
4. inlandpipe.com/direct-design
5. concrete-pipe.org/magazine/2014springcpnews.html (Page 7)
6. [ccppa-ca.web35.winsvr.net/Portals/0/CPJ/CPJ_Winter2015-forweb\(1\).pdf](http://ccppa-ca.web35.winsvr.net/Portals/0/CPJ/CPJ_Winter2015-forweb(1).pdf) (Page 6)
6. pedrecontractors.com

Learn More About Buried Infrastructure

- **Keyword Search on American Concrete Pipe Association Website** (storm, standard, installation, SPIDA, bedding direct, indirect) concrete-pipe.org
- **Concrete Pipe Design Manual** concrete-pipe.org/pages/design-manual.html
- **Concrete Pipe News** concrete-pipe.org/pages/cpnews.html

ACPA Standard Installations brochure
concrete-pipe.org/pdf/standard-installation.pdf



Type 2 Standard Installation of 1800mm RCP on Powell Street Overpass project in Vancouver, B.C.



Photos: Courtesy of Andrew Cortese, P.Eng., Ocean Pipe



American **Concrete Pipe** Association
8445 Freeport Parkway, Suite 350
Irving, TX 75063-2595

www.concrete-pipe.org

PRESORTED
STANDARD
US POSTAGE PAID
DALLAS, TX
PERMIT NO 1883

Eric M. Yount Receives Longfellow Award

The 2015 recipient of the Richard C. Longfellow Award was Eric M. Yount, Nevada Department of Transportation. His article, "[*Sustainable Precast Concrete Boxes for Resilient Infrastructure*](#)"¹ was published in the Spring 2014 issue of Concrete Pipe News, Page 5.

Deconstruction and reconstruction of a triple-cell culvert on SR-160 in Las Vegas, Nevada is an example of reusing precast concrete boxes to reconstruct the culvert element of Nevada's highway infrastructure.

Each year, a Concrete Pipe News author is honored with the award for an article that most effectively demonstrates innovative and effective use of concrete pipe. The award is presented in memory of Richard Longfellow who had an outstanding career with Cretex Companies, Inc. based in Elk River, Minnesota.

LINK TO ARTICLE

1. concrete-pipe.org/magazine/2014springcpnews.html



Save this link concrete-pipe.org/pages/cpnews.html to your favorites list to increase your knowledge about drainage applications and innovative ways to use precast reinforced concrete pipe and boxes to build structures that will last.