

Volume 53 No. 1 Spring 2001

concrete pipe news

The Magazine of the American Concrete Pipe Association

Precast Concrete Box Culvert System

A New Solution for an Old Drainage Problem

- Specially Designed Microtunneling RCP Meets Challenging Site Conditions
- Precast RCP Provides Welcome Relief to Residents and Merchants on Cape Cod
- Concrete Pipe Joints — Your Best Choice



This issue:

Volume 53, Number 1
Spring 2001

Concrete Pipe News is designed to provide a communication forum for the concrete pipe industry to facilitate the exchange of information regarding product use and applications, industry technology and trends among members of the American Concrete Pipe Association, contractors, engineers, vendors, suppliers and other interested parties.

American Concrete Pipe Association Staff

John J. Duffy
President

Mike Saubert
Director of Marketing

Josh Beakley
Director of Technical Services

Matt Childs
Director of Engineering Services

Carol LeSueur
Director of Member Services

Wendy Lambert
Controller

Media Task Group

Scott Olson, Chairman
*The Cretex Companies
Elk River, Minnesota*

Bill Gardner
*Madison Concrete Pipe, Inc.
Madison, Wisconsin*

Walter Krahn
*Inland Pipe Limited
Calgary, Alberta*

Bill Hobson
*N.C. Products Corp.
Raleigh, North Carolina*

Merle Headington
*Zeidlers, Inc.
Waterloo, Iowa*

Contract Editorial Staff

A. Grant Lee
*AGL Marketing Limited
Executive Editor*

Gary Wilder
*Wilder Studios
Production*

Published by:

American Concrete Pipe Association
222 W. Las Colinas Blvd., Suite 641
Irving, Texas 75039-5423
Phone: (972) 506-7216
Fax: (972) 506-7682
E-mail: info@concrete-pipe.org



Opinions expressed by authors other than staff of the American Concrete Pipe Association do not necessarily reflect the official positions or policies of the Association.

Table of Contents

Regular Departments

President's Report 3

From Association President John J. Duffy

Industry Spotlight 4

Roman Selig, Director of Marketing and Engineering at Sherman International Corporation in Birmingham, Ala., has been a principal force in setting the direction of ACPA marketing programs. Roman believes in paying attention to details, and focuses on facts that often are overlooked.

Features

Precast Concrete Box Culvert System Solves Ten-Year Drainage Problem 5

A precast concrete box culvert system was installed quickly in Charlotte, N.C., to limit disruption to local traffic. It saved the City design and quality control costs, and its precast components were manufactured in a controlled environment according to stringent quality standards.

Specially Designed Microtunneling Pipe Engineered for Challenging Site Conditions 8

Designers of a sanitary sewer installed in Milwaukee, Wis., made use of ASTM standards and local studies and investigations to determine the design of the precast reinforced concrete pipe and microtunneling technology needed for the installation.

Reinforced Concrete Pipe Replaces Failed HDPE Installation 10

Business owners along historic Main Street (Route 6A) in Barnstable, Mass., were relieved when most of a failed HDPE drainage system was replaced with reinforced concrete pipe.

Concrete Pipe Joints — Your Best Choice 12

During the past four decades, there have been major improvements in joint design and production of precast concrete pipe. Today's precast concrete pipe offers several types of joints that meet stringent industry and national standards for performance.

*Cover Photo:
The first of two parallel
lines of
8-foot x 5-foot precast
concrete box culverts
being installed along
Sedley Road.*

*Inset Photo:
Tree-lined streets in the
Charlotte, N.C.- area.*





John J. Duffy

Water Infrastructure Network Gaining Momentum

The concrete pipe industry is gearing up to support a significant financial investment in America's water and wastewater infrastructure. The American Concrete Pipe Association has joined forces with leading advocacy groups, such as the Association of Metropolitan Sewerage Agencies (AMSA), American Water Works Association, and Water Environment Federation to form the Water Infrastructure Network (WIN). Together, we have the collective means to effect legislative change that would release funds for major infrastructure projects, including sanitary sewer and storm water drainage systems.

On February 13, WIN called for Congress to pass legislation this year to renew the nation's commitment to clean and safe water. The "Network" calls for a five-year, \$57 billion federal investment in drinking water, sewer, and stormwater infrastructure to replace aging pipes, upgrade treatment systems, and continue to protect public health and the environment. The report released by WIN, entitled *Water Infrastructure Now*, states that the funding increase is urgently needed to help close a \$23 billion per year gap between infrastructure needs and current spending.

The ACPA encourages its members and friends in the industry to contact the Water Infrastructure Network and find out how to get involved.

In Canada, there have been similar calls to action, and pressures brought to bear on federal and provincial governments. Although the federal government has earmarked only \$CAD 400 million per year for infrastructure (water/sewage, roads and affordable housing) over five years for the entire nation, it is a start, and ministers will continue to hear the call for increased funding. In Ontario, the provincial government has provided municipalities with access to over \$CAD 200 million through a three-year Provincial Water Protection Fund.

The call for better infrastructure is a public issue that deals with service life, convenience, health and safety and affordability. "Public awareness" could be considered a theme for this issue of *Concrete Pipe News*. Two authors have contributed case histories of projects that involve greater public attention to drainage systems, and another shows how precast concrete pipe design can be made-to-order to deliver maximum performance.

A ten-year drainage problem in a neighborhood of Charlotte, N.C., is being solved with precast concrete box culverts, after a personal injury during a major storm event triggered community action in 1991. In Barnstable, Mass., local businesses and citizens were critical when high density polyethylene drain pipes buried beneath Route 6A failed, causing major disruption to travel and business. The system was replaced with precast reinforced concrete pipe.

Designers of a sanitary sewer in Milwaukee, Wis., installed by tunnel and open-cut had challenging site conditions over the length of the project. Since microtunneling is an installation technique that will be used more often in the future, the article shows how ASTM standards and public issues will affect design and material selection decisions.

Concrete pipe joints have changed significantly over the past forty years. ACPA staff engineers have prepared a technical paper for this issue that details the new technology used to join pipe, reducing infiltration and exfiltration, while allowing movement due to soil dynamics.

Our Industry Spotlight features Roman Selig, Director of Marketing and Engineering of Sherman

continued on page 14



Roman Selig

A sharp wit and thoughtful demeanor describe Roman Selig, the concrete pipe industry's frontrunner when it comes to paying attention to detail. When new concrete pipe standards are being developed, publications drafted, and hard-hitting presentations planned that deal with major industry issues, you can be sure that Roman is involved. He works quietly on many committees and subcommittees, making sure that details are understood, and challenges tradition when he believes there is a better way.

Roman is Director of Marketing and Engineering of Sherman International Corporation's Concrete Products Group in Birmingham, Ala., where he has been employed since 1987. He is a graduate of the University of Arkansas, with a B.S. in Civil Engineering, lettering in track and cross country. He served as an officer in the United States Army, including a tour with commendation in Vietnam.

The American Concrete Pipe Association is fortunate to be able to draw upon Roman's technical strengths and fortitude as a tireless volunteer. He has worked on many of the ACPA's committees and task groups. He is currently a member of the Marketing Committee and ACPA's American Association of State Highway and Transportation Officials (AASHTO) Task Group, and is past chairman of both.

In addition to his work with the ACPA, Roman serves the concrete pipe industry and Sherman International as a member of the Water Environment Federation (WEF), and American Society for Testing and Materials (ASTM). At ASTM, he serves on four subcommittees, and is vice chair of one. In addition, he is a member of the Transportation Research Board (TRB) as well as a committee member. Here are Roman's reflections and visions about a dynamic industry that has excelled in recent years, due to the



tireless work by people like Mr. Selig.

Q: *What features of the performance of concrete pipe do you believe that specifiers may be overlooking that would raise its profile as the product of choice, when compared to alternate drain pipe and tubing products?*

Selig: The three main aspects in the pipe material selection process should be durability, installation, and hydraulics. These are directly related to econom-

ics of the project and concrete pipe excels in all three, especially durability. Some designers and owners ignore long-term costs. It is more difficult, however, for an agency to obtain maintenance funds than original project funding. The installed cost and the superior hydraulic efficiency of concrete pipe are sometimes overlooked.

Q: *You are known as a "stickler for detail". Why do you consider the "details" to be so important?*

Selig: It is a curse. Just ask my wife or assistant. Fortunately, or unfortunately, things like typos just jump off the page at me. Early in my career, I had a boss who was a master letter writer and negotiator, and his example was a major influence on me. Good communication

is very important. However, with written communication, one does not have the give and take, as well as body language, that are present in verbal communication. There is essentially one shot with written communication. Also, if a letter or document contains spelling errors, or other deficiencies, then the recipient may focus on those and not give proper credence to the message.

Q: *Why is it important to look for the little things associated with an industry standard or product development, when so often, performance is the focus of attention?*

Selig: It is the little things in life and family that matter, as much as the big things. That is the case in business, too. Small problems, if not handled properly, grow into big problems. The little things in standards and product development can affect the performance. The concrete pipe industry is paying more attention these days to the details in mix design, joints, and other product features. We often focus on the small details in our promotional efforts against alternate products, especially when using their own literature.

continued on page 15

Reinforced Concrete Box Culvert System Solves Ten-Year Drainage Problem

By Tyson H. Hicks, E.I.T.
CSR Hydro Conduit, Thomasville, N.C.
800-475-6302

Over the past ten years, the neighborhood along Sedley Road in Charlotte, N.C., had experienced public safety problems associated with an open channel that traverses their community. The City of Charlotte responded to those problems by initiating a cost savings design and plan that incorporated precast concrete box units. The precast culvert was a welcome solution and relief to local residents and government officials alike.

Prior to being annexed into the city limits, the problems in the Sedley Road neighborhood were so serious that the residents had planned to raise funds to pay for the channel improvements themselves. Local residents proposed to pipe and enclose the Sedley Road Channel, citing the channel as an eye sore, a safety hazard for children and a general danger to the traveling public.

The drainage problems along Sedley Road escalated in 1991 during a large storm event. A car was washed off the road when the open channel overflowed. A person was severely injured, a lawsuit followed, and city officials settled with the plain-

tiff before the case went to trial. The city responded by allocating funds for the design and installation of a new culvert, and by securing permits from the Army Corps of Engineers, North Carolina Department of Natural Resources, and other agencies.

While action was being taken to introduce a comprehensive design solution, road conditions and safety suddenly deteriorated. The lane width of Sedley Road was reduced due to potential shoulder wash-outs and failure of a masonry headwall under a portion of Sedley Road.



Horizontal bend precast concrete box sections allow the drainage system to follow the existing drainage course along Sedley Road in Charlotte, N.C.

The city's Storm Water Division made a recommendation to use precast concrete box units, instead of a cast-in-place structure for several reasons. The project manager noted that project time restraints played an impor-

tant role in the decision of using a precast reinforced concrete culvert system. He said, “The speed at which the concrete boxes could be installed, and the road reopened to local residents was an underlying reason for recommending precast box units. Experience has shown that most cast-in-place structures take longer to construct due to form setup, in-place concrete cure time, and dealing with adverse weather conditions. With a precast culvert system, the road was closed and reopened within one week.”

The project manager also said, “The project design and permitting costs ran approximately \$30,000. Using precast allowed the city to save nearly 20% in design and quality control costs. When an engineer specifies precast concrete box units, it is generally the manufacturer’s responsibility to develop the structural design and plans for the culvert.”

The City of Charlotte furnished CSR Hydro Conduit Engineer, Wayne Hodge, P.E., and Engineering Technician, Brad Allen, with the anticipated culvert loading criteria and culvert

location. From this information, CSR determined the steel reinforcement requirements in accordance with ASIM

C 789, “Standard Specification for Precast Reinforced Concrete Box Sections for Culverts, Storm Drains and Sewers.” CSR personnel also provided the city with a layout schedule with box unit details for the project.

The final culvert layout included two parallel lines of (8-foot x 5-foot) precast box culverts that were 106 feet in length. Due to local environmental protection regulations, the city required two horizontal bends that enabled the layout to follow the existing drainage course. In addition, a box unit with a manhole opening was provided to accommodate an existing 30-inch storm drainage line. Finally, two precast concrete box units were provided with additional wall steel so that a flow equalization hole could be cored in the field during the second phase of the project. Construction of the first phase was initiated in late 2000.

According to the project manager, “Precast concrete box units allowed the city to have greater quality control over the final product. If we had opted for a cast-in-place structure, our quality control time and costs would have been much higher.” He also noted that ASTM C 789 specifies the in-plant quality measures that the precast product must meet.

The Charlotte Storm Water Services maintenance team most often undertakes emergency projects, such as the first phase of the Sedley Road Project. Each year, the City of Charlotte sets up several maintenance contracts for bidding. Contractors bid on the contract just as they would for a specific project. Pay items included in the contract are pipe laying, excavation, miscellaneous drainage structure work, and repair. These items in the maintenance contract allowed the city to release the culvert work to Blythe Construction with-

Use of precast concrete box sections limited disruption to local traffic and services, and were supplied quickly by the ACPA member.



out the need of letting the project for bid, hence speeding its completion.

Phase Two of the Sedley Road Project also involves the installation of precast concrete box units, just like the ones installed as part of the emergency repair. The city is waiting for approval of environmental permits to proceed with the work. Unlike the emergency repair, the installation of an additional 800 feet of box culvert will bid like all of Charlotte’s capital improvement projects.

Residents and city officials worked together to solve a very difficult drainage problem. The precast concrete box culvert system was installed quickly to limit disruption to local traffic and services; it saved the city design and quality control costs, and its precast components were manufactured in a controlled environment according to stringent quality standards. The precast reinforced concrete box solution will ensure decades of service so that residents might fully enjoy the natural environment and services in their neighborhood. ☺

Editor’s Note: ASTM C 789 for precast box culverts with 2 feet or more of fill (and ASTM C 850 for precast box culverts with less than 2 feet of cover subjected to highway loadings) have been superseded by ASTM C 1433, “Standard Specification for Precast Reinforced Concrete Box Sections for Culverts, Storm Drains and Sewers.”



The final layout included two parallel lines of 8-foot x 5-foot precast concrete box sections.

Project:	Sedley Road Culvert Drainage Improvements
Owner:	City of Charlotte, N.C. Storm Water Services Anthony H. Dudley, Senior Project Manager
Designer:	Concord Engineering Jill Brim, P.E. CSR Hydro Conduit Wayne Hodge, PE, Corporate Engineer Allen Brad, Engineering Technician
Contractor:	Blythe Construction, Inc., Charlotte, N.C. Tim Britts, Project Manager
Quantities:	106 linear feet of parallel (8-foot x 5-foot) reinforced concrete box units Two horizontal bends (special box units) One box unit with manhole opening Two special box units designed for flow equalization control
Producer:	CSR Hydro Conduit, Thomasville, N.C. John Peter, EIT, General Manager Tyson H. Hicks, E.I.T., North Carolina Area Sales Engineer

CSR Hydro Conduit-Thomasville, a division of CSR America, and a long-time member of the American Concrete Pipe Association, has been manufacturing and supplying precast box culverts for the North Carolina area since the early 1980s. CSR Hydro Conduit operates over 80 manufacturing plants nationwide. With four Carolinas facilities, CSR maintains a comprehensive line of precast products, utilizing the latest in manufacturing and production technologies for the creation of reinforced concrete pipe (round and elliptical), precast box culverts, and a variety of associated products including catch basins, flared inlets, and end treatments. For more information on CSR Hydro Conduit, visit: www.csrhydroconduit.com.

Specially Designed Microtunneling Pipe Engineered for Challenging Site Conditions

By John J. Meyer, P.E., General Manager • American Concrete Pipe Company, Milwaukee, Wis. • 414-466-4990

Microtunneling projects are now accepted as viable alternatives to traditional open-cut installations in situations where there are major environmental, economic and urbanization issues. What sets concrete pipe applications apart from alternative materials is the ability to prepare unique designs of the concrete mix — and the design of the pipe itself — for site-specific applications.

Designers of a sanitary sewer, installed in Milwaukee, Wis., in late 1999 by tunnel and open-cut methods had challenging site conditions over the length of the project. They made use of ASTM standards and numerous local studies and investigations to determine the design of the precast reinforced concrete pipe and microtunneling technology needed for the installation. This installation proved the need for ASTM standards for jacked/microtunneling pipe, as the technology was successful, and will be used more often in this century.

The microtunneling project, authorized by the Milwaukee Metropolitan Sewerage District, required 3,200 feet (975 m) of 30-inch (750-mm) diameter C 76 Class IV reinforced concrete microtunnel pipe to be installed at depths up to 64 feet (19 m). This specific design of the pipe was submitted to the owners by the installer, and was accepted as an equal alternative to the original specification. Known as the Ramsey Avenue Relief Sewer, it was constructed to increase the Metropolitan Interceptor Sewer capacity in southern Milwaukee.

The installation method of tunneling was initially considered for this project because of the topographic conditions. Depths of the line varied from 23 feet (7.0 m) in some areas of the installation to depths approaching 64 feet (19.5 m). When historic topographic maps were compared with the existing built environment, it was apparent that there

had been an increase in residential properties scattered throughout the project corridor, and some commercial development, making the microtunneling option even more economically sound.

Soil borings were taken as part of a combined



Top: Construction shafts were located along Ramsey Avenue for the sanitary sewer project in Milwaukee, Wisconsin.

Bottom Left: A section of the specially-designed microtunneling pipe is lowered into the jacking pit.

Bottom Right: Crew members position the microtunneling pipe in the jacking cradle.

Phase I and Phase II environmental assessment of the site. Borings were advanced to depths of 11 to 21 feet (3.4 to 6.4 m) below ground surface, and three

were converted to groundwater monitoring wells. The soils in the project area are generally comprised of fill, consisting of silty clays, silt, sand and gravel to depths of 6.5 to 10 feet (2.0 m to 3.0 m). The fill soils are underlain by silty clays, and clayey silt with sand seams and gray silty clays. The depths to groundwater at the project corridor were expected to range from approximately 9 to 13 feet (2.7 m to 4.0 m) below ground surface. The depth to groundwater was expected to vary due to rainfall, surface run off, seasonality and other environmental factors. Groundwater flows east/southeast toward Lake Michigan.

The on-site reconnaissance included visual observation for the presence of above-ground storage tanks, septic systems, fill areas, depressions, distressed vegetation, and other indicators of potential environmental concern. A site history evaluation and regulatory search was performed for the properties within a quarter mile (402 m) of the project corridor by interviewing local officials and reviewing state records and EPA databases. Eight sites were identified as potential hazardous materials sites within a quarter mile of the project corridor. One site held the possibility of encountering petroleum impacted soils during excavation for sewer construction, and another held the possibility of migration of potential petroleum contamination from the property to the Ramsey Avenue right-of-way.

The design engineer used ASTM specifications as the basis for design and testing to assure staff at the District that it would be receiving the product that would meet the District's requirements. Pipe that was used for 410 linear feet (125 m) in open-cut was thoroughly specified through the use of ASTM standards. The appropriate ASTM specifications address the wall thickness, the concrete strength, and the area, type, placement, number of layers and strength of the steel reinforcement, gaskets and joint design. Testing of randomly selected pipe was addressed through applicable ASTM specifications.

The reinforced concrete pipe that was to be provided for jacking needed to be modified beyond the requirements of ASTM C 76, Standard Specification for Reinforced Concrete Culvert, Storm Drain, and Sewer Pipe. The modifications were necessary because ASTM C 76 is designed for transverse (earth) load, not the axial load that is experienced by the pipe during the jacking operation. Fortunately, many

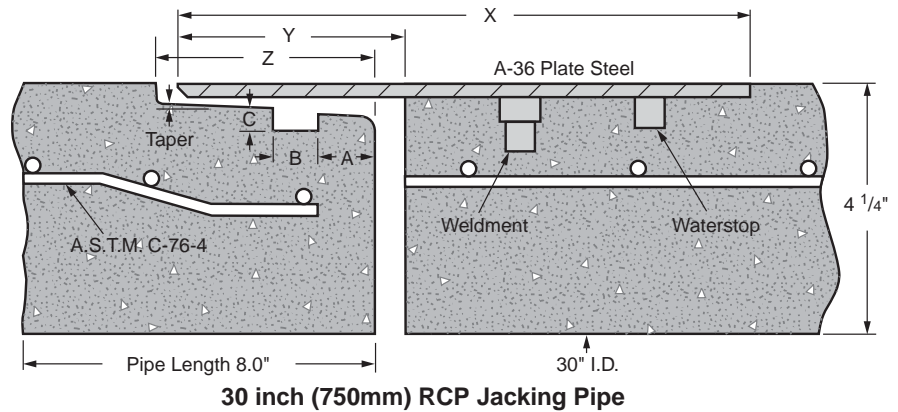

designers, producers, and installers have experience with jacking pipe, and as a team, they were able to provide significant knowledge of the necessary modifications. But once those modifications were incorporated into the finished pipe, the pipe was tested with methods similar to testing an open-cut C 76 pipe.

By working with the installation contractor, the pipe manufacturer was able to design a pipe to meet the requirements of the contract documents and the needs of the contractor. The use of the structural requirements for C 76, as a minimum, allowed the

continued on page 14

Project:	Ramsey Avenue Relief Sewer
Owner:	Milwaukee Metropolitan Sewerage District Larry Ellis, P.E.
Designer:	Kapur and Associates, Inc. Thomas R. Wagner P.E.
Contractor:	Michels' Pipeline Brownsville, Wisconsin William Weltin, P.E.
Quantities:	3,200 feet (975 m) of 30-inch (750-mm) diameter C 76 Class IV reinforced concrete microtunnel pipe
Producer:	American Concrete Pipe Company Milwaukee, Wisconsin John J. Meyer, P.E., General Manager

The Spancrete Group and its subsidiaries are a full service provider of concrete building products and machinery serving the Greater Midwest Region. American Concrete Pipe Company is one of the subsidiaries with concrete pipe plants located in Green Bay and Milwaukee, Wisconsin. For information about Spancrete and its subsidiaries, see www.spancrete.com.

REINFORCED CONCRETE PIPE REPLACES FAILED HDPE STORM DRAIN INSTALLATION

*By Stephen Berlo, Sales & Marketing
Scituate Concrete Pipe Corporation, Scituate, Mass.
800-322-4488*

Failure of a significant portion of a high density polyethylene pipe (HDPE) storm drain installation in Barnstable, Mass., led to prolonged economic losses to local merchants and inconvenience to the traveling public. The failure can be attributed to selecting a product that was not appropriate for the application; a classic case that underscores the importance of completely understanding the performance of drainage products. The problem was solved by replacing much of the HDPE system with Class III and Class V reinforced concrete pipe (RCP) produced by Scituate Concrete Pipe, Scituate, Mass. However, the social and economic damage to the community will take some time to pass.

The contract for the installation of 400 feet of HDPE storm sewer beneath Route 6A, the main street of Barnstable, was awarded to P.A. Landers in the summer of 1998.

1. Significant portions of the HDPE pipe failed.
2. Much of HDPE pipe had to be removed and replaced.
3. 48" Class V precast reinforced concrete pipe ready for installation along Route 6A.
4. Crews worked quickly to replace the failed HDPE pipe with RCP.
5. Barnstable residents and merchants were happy when the project was completed.

The drainage and road reconstruction project was scheduled to take six months to complete. This was a big issue to local merchants, as the town is a major tourist attraction on Cape Cod during the spring, summer, and fall months. Merchants expected some economic distress during construction as local residents and tourists avoided the downtown core as much as possible, following detours during construction.

The consulting engineer on the project recommended an installation using Class V precast reinforced concrete pipe. However, the recommendation was over-ridden by town officials and a contract for a HDPE installation was awarded. The award of the contract did not go uncontested by Scituate staff. Scituate Concrete Pipe appealed to the town's officials on behalf of the consulting engineer and contractor, explaining that the HDPE product would be hard pressed to perform structurally at depths up to 15 feet in some locations and as shallow as one foot of cover elsewhere. In addition, the site had a very high water table raising concerns of proper bedding and flotation.

The Scituate staff and contractor also explained to town officials that the cost of installing a concrete pipe storm sewer would cost less than HDPE. Again, the city was not persuaded and work orders were issued for the construction of the HDPE storm drain.

In October 1998, following completion of the HDPE installation, the inspection crew checked catch basins and manholes for as-built conditions. They reported that in some places, the system was full of water and debris, over deflected, and collapsed. Plastic storm drains under the street were collapsing under the weight of the road. Consequently, the town's engineers, consulting engineer and contractor agreed that most of the entire system of 48, 24 and 18-inch diameter HDPE storm drain had to be removed and replaced with a reinforced concrete pipe system.

Downtown merchants and local residents were understandably very upset. A local tavern restaurant owner questioned the use of HDPE and stated, "Why didn't they use concrete pipe in the first place? Now I'm out of business for another six months."

Once the decision was made to proceed with a reinforced concrete pipe system, the contractor

approached Scituate and ordered 400 feet of 48-inch diameter Class V RCP, along with 18-inch diameter and 24-inch diameter Class III RCP. The delivery schedule was "ASAP".

On April 17, 1999, the local paper, Cape Cod Times, reported that street pavers were out the day before to complete the final phase of work, after reinforced concrete pipe had been installed earlier that month. The town was fortunate that it was able to complete the project within its original budget of \$1.6 million. Nevertheless, the HDPE storm drain failure provided a valuable lesson, and the true cost of the replacement may have been borne by the residents and local merchants. As the Barnstable tavern owner said in the Cape Cod Times on April 17, "It's Independence Day in Barnstable Village. I'm celebrating twice this year, on July 4 and the day the last truck drives out of here." That summed up the feeling of many people involved in the project. ☺

Project:	Barnstable Drainage and Road Reconstruction
Owner:	Town of Barnstable
Consulting Engineer:	Goodkind & O'Dea, Inc. Boston, Mass.
Contractor:	P.A. Landers, Inc. Hanover, Mass.
Quantities:	400 feet: 48-inch diameter Class V RCP 18-inch diameter and 24-inch diameter Class III RCP
Producer:	Scituate Concrete Pipe Corporation Scituate, Mass.

Scituate Concrete Pipe Corporation has recently rejoined the American Concrete Pipe Association. Established in 1959, the company provides products to Maine, Connecticut, Massachusetts, Vermont, New Hampshire and Rhode Island. Products available include reinforced concrete pipe, precast concrete sanitary and drainage utilities, and precast and concrete arches and structures.

CONCRETE PIPE JOINTS, YOUR BEST CHOICE

By Matt Childs, P.E., Director of Engineering Services
American Concrete Pipe Association
972-506-7216

Concrete pipe has been used for several different purposes since the ancient days of man. In North America, concrete pipe has been used extensively in drainage and sanitary sewer systems since the 19th century. Technology advancements in industry over the last century have led to major improvements in the concrete pipe manufacturing processes, mix designs, strength, reinforcement, new products, and installation designs. One area that has continued to evolve and progress along with the rest of the concrete pipe industry is joint design and production. Today's concrete pipe offers several types of joints that meet stringent industry and national standards for performance.

The function of a pipeline generally determines the performance requirements of the pipe joints. Whether the purpose is to convey sanitary sewage or stormwater, joints are designed so that when sections are laid together they will make a continuous line of pipe with an interior free from irregularities. Joints can be designed to provide soil-tightness, or watertightness, with the ability to accommodate lateral or longitudinal movement, and strength to handle shear or vertical movement.

Concrete pipe manufacturers have developed joint designs to provide the following performance characteristics:

- Resistance to infiltration of groundwater and backfill material
- Resistance to exfiltration of sewage or storm water
- Ability to accommodate lateral or longitudinal movement
- Strength to handle shear or vertical movement
- Pipeline continuity and smooth flow line
- Allowing infiltration of groundwater for subsurface drainage
- Ease of installation

In addition to the advantages of the concrete pipe joints mentioned above, the increased number

of joints, typically marketed by competing products as a perceived shortcoming of concrete pipe, may in fact be an advantage for many installations. With an increased number of joints: line and grade is maintained and checked more frequently, pipe lengths can fit and be positioned in standard trench boxes more easily, and longitudinal stresses in pipe walls are relieved when pipelines encounter non-uniform bedding foundations.

The concrete pipe industry offers several joint systems to satisfy this broad range of performance requirements. Consultation with local concrete pipe manufacturers will provide information on the availability of the various joints.

CONCRETE PIPE JOINT SYSTEM OPTIONS

Precast Concrete pipe joints are manufactured in three basic shapes:

- Modified tongue and groove
- Tongue and groove
- Bell and spigot

Concrete surfaces with opposing shoulders on both ends, such as the bell and spigot and the modified tongue and groove joints, generally utilize a rubber gasket for sealing. Preformed flexible joint sealants or mortar are used for lesser performance requirements or where the product shape dictates the type of seal.

A. Mortar

For mortar joints, a layer of cement paste or mortar is placed in the lower portion of the bell or groove of the installed pipe and on the upper

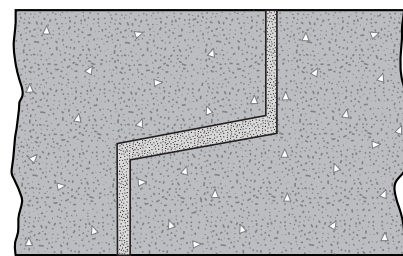

Typical cross-section of joint with mortar packing.

portion of the tongue or spigot of the pipe section to be installed. The tongue or spigot is then inserted into the bell or groove of the installed pipe until the sealant

material is squeezed out onto the interior or exterior surfaces. Joints employing mortar joint sealants are rigid. Mortar joints have been used successfully as a soil-tight joint for many years.

B. Preformed Flexible Joint Sealants

Bitumen and butyl sealants are manufactured in accordance with ASTM C990 *Standard Specification for Joints for Concrete Pipe, Manholes, and Precast Box Sections Using Preformed Flexible Joint Sealants*. The sealant is applied to the

tongue or spigot and inserted into the bell or groove. Joints utilizing flexible mastic sealants

typically perform as a soil-tight system unless higher performance expectations are described in the project specifications. If properly applied, these joints provide a

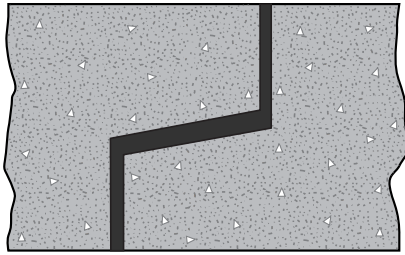

Typical cross-section of joint with flexible mastic sealant.

degree of flexibility without impairing watertightness. However, they are not intended to operate under internal pressure.

C. Rubber Gasket Joints

Concrete joints with a groove or offset on the spigot and/or bell utilize a rubber gasket, which fits against the shoulder or in the groove of the

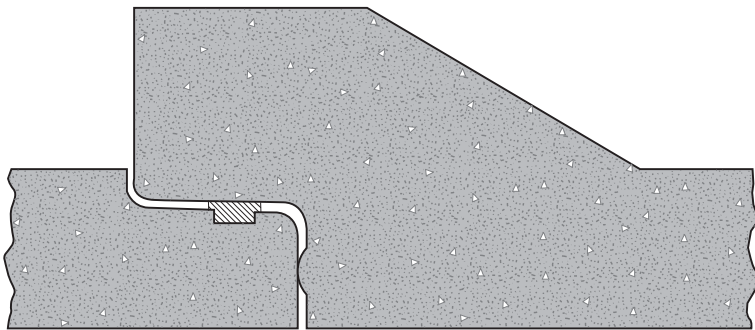

Typical cross-section of opposing shoulder type joint with a confined o-ring rubber gasket.

joint. Rubber gasketed concrete pipe joints are frequently used where infiltration/exfiltration and/or pressure is a factor in the design. This joint combines great shear strength, excellent watertightness and flexibility. There are a wide variety of rubber gasket joints from which to choose, but they must meet certain stringent requirements included in ASTM C 443 *Standard Specification for Joints for Circular Concrete Sewer and Culvert Pipe, Using Rubber Gaskets and C361 Standard Specification for Reinforced Concrete Low-Head Pressure Pipe*.

D. External Sealing Bands

External flexible sealing bands are produced to ASTM C877 *Standard Specification for External Sealing Bands for Noncircular Concrete Sewer, Storm Drain, and Culvert Pipe* and are designed to be wrapped around the exterior of the joint to



Example of an installation of external sealing bands around elliptical concrete pipe.

provide resistance to infiltration and/or exfiltration.

Design engineers need to be aware of what is and is not included within suggested pipe standards for their projects. When comparing the performance of pipe jointing

systems between concrete pipe and alternate products, one should review the standard specifications of each product. Two of the bodies most often referred to are the American Society for Testing and Materials (ASTM) and the American Association of State Highway and Transportation Officials (AASHTO). ASTM standards are consensus based standards that exist for both storm and sanitary sewer joints. The AASHTO standards for storm sewers and culverts are developed by the 50 State Highway or Transportation Departments, the District of Columbia, and Puerto Rico. Many ASTM and AASHTO specifications are identical or "sister" specifications. The AASHTO standards are intended to serve as a standard for the preparation of state DOT specifications, whereas ASTM standards are typically referenced in other applications.

ASTM C 443 (AASHTO M315) covers rubber gasketed, watertight joints for circular concrete sewer and culvert pipe and precast manhole sections. The specification includes both the design of joints and the physical requirements for rubber gaskets to be used therewith. ASTM C 443 requires acceptability of concrete pipe joints and gaskets based on the results of proof-of-design tests.

CONCLUSIONS

As infiltration and exfiltration standards have changed considerably over the last century, so has the performance of concrete pipe and concrete pipe joints. Concrete pipe offers the design engineer several different joint types depending on the application. The joint types include mortar, flexible sealants, rubber gaskets, and external sealing bands. Throughout North America concrete pipe manufacturers routinely meet demanding project specifications. Because of its superior durability, strength and joint system performance, concrete pipe remains the pipe of choice for engineers and owners of drainage and sanitary sewer projects. ☺

President's Message

continued from page 3

International Corporation's Concrete Products Group in Birmingham, Ala. When new concrete pipe standards are being developed, publications drafted, and hard-hitting presentations planned that deal with major industry issues, you can be sure that Roman is involved.

The concrete pipe industry is doing its job to deliver long-lasting buried infrastructure by producing high quality products in standard units, or specially designed for challenging situations. In the United States and Canada, concrete pipe associations and their members have willingly taken a stand, and continue to voice their positions supporting long-term investment in infrastructure. Public awareness of the need for precast concrete pipe has become local news. The concrete pipe industry is ready to support organizations like WIN, where the public interest in a safe and healthy infrastructure is at stake. ☺

Microtunneling

continued from page 8

contract document requirements to be met. The next step was to determine the additional requirements of the contractor for the pipe's final design. Two critical items noted were having adequate pipe jacking capacity and the proper outside diameter to match the contractor's microtunnel machine. Concrete strength was increased from the required 4000 pounds per square inch (27.6 MPa) of C 76 to 5400 pounds per square inch (37.3 MPa) to give the pipe a jacking capacity of 390 tons (3470 kN) including the project's required safety factor. This gave the pipe adequate strength to handle the jacking capacity of 300 tons (2780 kN) delivered by the microtunneling machine. In addition the surface area of the bell was increased to accommodate a wider steel ring, and this added strength to the pipe joint. The pipe was produced with an outside diameter of 38.5 inches (978 mm) to meet the contractor's overcut requirements for his machine which measured 39.4 inches (1000 mm).

The Class IV, C-wall pipe had 5400 pounds per square inch compressive strength for the concrete. The pipe joint conformed to ASTM C 443, "Standard Specification for Joints for Circular Concrete Sewer and Culvert Pipe Using Rubber Gaskets." But, it was not a typical concrete joint. The joint consisted of an external joint ring that was machined from A-36 plate steel and was coated with two-part coal-tar epoxy. This special design of the joint provides the contractor a degree of "steer-ability" during installation in the type of ground conditions that were encountered at the jobsite.

The contractor's microtunneling machine and the tunneling pipe were specifically designed for the anticipated soil conditions. The largest drive of the project was 676 feet (206 m) followed closely by a push of 670 feet (204 m). Both of these drives were completed with jacking pressures well under the design strength of the pipe and without the aid of intermediate jacking stations.

The Ramsey Avenue Relief Sewer project clearly demonstrates that reinforced concrete pipe can be modified within existing ASTM standards to meet unique site conditions that challenge typical sewer installations. Precast reinforced concrete pipe has the inherent quality of being adaptable to just about any situation for which it might be considered. ☺

(Adapted with permission, from STP 1368-Concrete Pipe for the New Millennium, copyright American Society for Testing and Materials, 100 Barr Harbor Drive, West Conshohocken, PA 19428.)

CORRECTION

Concrete Pipe News, Volume 52, No. 4
Winter 2001, page 12

De-mystifying Manning's *n*: The Hydraulic Advantage of Reinforced Concrete Pipe, Al Hogan, P.E. Sherman Dixie Concrete Industries, Inc., as compiled and edited by Matt Childs, P.E., American Concrete Pipe Association.

The "promoted value" of Manning's *n* for PVC-smooth wall in Table 1: Recommended Values of Manning's *n*, was incorrect. The correct "promoted value" should be 0.009. A corrected version of Table 1 is shown below. We apologize for this oversight.

Type of Pipe	Values of Manning's <i>n</i>		
	Lab Values	Promoted Values	ACPA Recommended Values
Concrete	0.009 - 0.010 ¹	0.010 - 0.012 ¹	storm sewer - 0.011 - 0.012 ¹ sanitary sewer - 0.012 - 0.013 ¹
Plastic Pipe HDPE smooth wall	0.009 - 0.015 ²	0.010 ³	storm & sanitary sewer - 0.012 - 0.020
PVC smooth wall	0.009 - 0.011 ⁴	0.009 ⁴	storm & sanitary sewer - 0.011 - 0.013
Corrugated Metal	0.012 - 0.030 ⁵	0.012 - 0.026 ⁶	0.021 - 0.029 ⁷

Roman Selig

continued from page 4

Q: How do you know when the details of a publication or pipe performance research project have been dealt with properly, and it is time to move ahead to closure?

Selig: When the information, as presented, is totally correct and the desired message has been conveyed. Ideally, the best document is one that is not vulnerable to “valid” counterclaims. This is an area where I feel our industry does a much better job than our competition.

Q: You have often commented how pleased you are to see young people in the industry getting involved in ACPA projects and programs. Why do you say this?

Selig: History is important. By association with older ACPA members, the young people in our industry will be better equipped for the future. But, it is not all about history. Networking is very important. It helped me to learn and perform my job better when I first joined this industry, and it still does. This is one of the reasons I actively participate in industry related associations. I commend my supervisors and the executives of other companies who recognize the importance of this need.

Q: Where do you see our industry, its products, and quality assurance programs in 10 years?

Selig: Our industry has made great strides in the last five to ten years. If our leaders continue on the same visionary course, if we have continued willingness of participation, and if we continue to recognize and hire talented people, then we will remain on top. I am including our associate members in this reference. Their accomplishments and improved involvement have contributed greatly to our success. And, do not forget humor. I think a little laughter in the workplace goes a long way, especially in reducing stress and strain. ☺

“Quality Cast” Certified Plants

In an effort to improve the overall quality of all concrete pipe products, the American Concrete Pipe Association offers an on-going quality assurance program to member and non-member companies. Called the “Quality Cast” Plant Certification Program, the 124-point audit-inspection program covers the inspection of materials, finished products and handling/storage procedures, as well as performance testing and quality control documentation. Plants are certified to provide storm sewer and culvert pipe or under a combined sanitary sewer, storm sewer and culvert pipe program. The following plants have been certified under ACPA’s Quality Cast Certification Program:

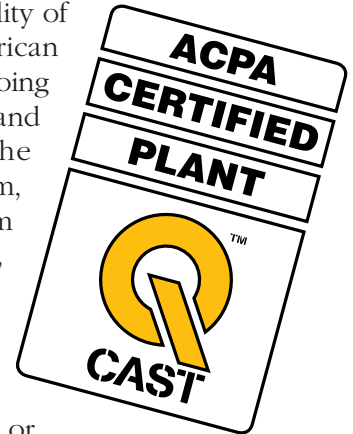

Storm Sewer and Culvert Pipe

- Cayuga Concrete Pipe Company (Oldcastle, Inc.), New Britain, PA
Edward Pentecost
- Elk River Concrete Products (Cretex), Billings, MT
Milton Tollesrud
- South Dakota Concrete Products (Cretex), Rapid City, SD
- Riverton Concrete Products Company (Cretex), Riverton, WY
Butch Miller
- Sherman-Dixie Concrete Industries, Inc., Chattanooga, TN
Earl Knox
- Sherman-Dixie Concrete Industries, Inc., Franklin, TN
Roy Webb
- Tarmac America, Inc., Charleston, SC
Bill Gary
- W.R. White Company, Hurricane, UT
Brent Field

Sanitary Sewer, Storm Sewer and Culvert Pipe

- Advanced Pipes & Cast Company, Abu Dhabi, United Arab Emirates
Poul Jacobsen
- Amcor Precast (Oldcastle, Inc.), Nampa, ID
Mike Burke
- Amcor Precast (Oldcastle, Inc.) Ogden, UT
Tim Wayment
- CSR Hydro Conduit Corporation, Tulsa, OK
Jeff Bassett
- Elk River Concrete Products (Cretex), Elk River, MN
Bryan Olson
- Geneva Pipe Company, Orem, UT
Fred Klug
- Kansas City Concrete Pipe Co. (Cretex), Shawnee, KS
Rich Allison
- N.C. Products (Oldcastle, Inc.), Fayetteville, NC
Preston McIntosh
- Ocean Construction Supplies Ltd. (Inland Pipe), Vancouver, BC
Rod Boyes
- W.R. White Company, Ogden, UT
J. P. Conn

Evaluating Pipe Installation Cost Is Easy with CAPE™ Software

CAPE™ (Cost Analysis - Pipe Envelope) Software from the American Concrete Pipe Association (ACPA) is the perfect tool for design engineers, estimators and contractors to use in determining the real cost of pipe installation. The program takes into account the many factors that affect the cost of installation for both rigid and flexible pipe, such as type of standard installation, in-site materials, haulage costs, inspection costs, and trench parameters.

CAPE is a sub-program of the ACPA's popular PipePac® 2000 software. The stand-alone version of CAPE provides only the tools needed to evaluate installation costs without being prompted for information required for pipe design, or life cycle analysis

(LCA) calculations. Using the Microsoft Windows-based operating system, the user-friendly input routines that are incorporated in CAPE Version 1.1, require only minimal experience using computers. The user controls most parameters of the program.

To order, contact the ACPA Resource Center at (800) 290-2272, fax (972) 291-0622 and request Item #15-905 (CAPE). The cost is \$4.00 (ACPA member) and \$ 8.00 (non-member), plus shipping and handling charges. All orders must be prepaid. Visa, MasterCard

and American Express are accepted. For further information contact the American Concrete Pipe Association, (972) 506-7216, or e-mail: info@concrete-pipe.org. ☺

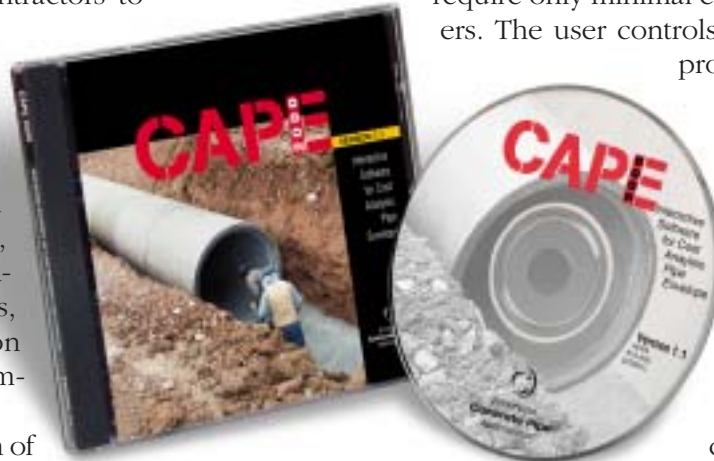

American **Concrete Pipe** Association
222 W. Las Colinas Blvd., Suite 641
Irving, TX 75039-5423

www.concrete-pipe.org

PRESORTED
STANDARD
US POSTAGE PAID
DALLAS, TX
PERMIT NO 1883