

Highway Live Loads on Concrete Pipe

FOREWORD

Thick, high-strength pavements designed for heavy truck traffic substantially reduce the pressure transmitted through a wheel to the subgrade and, consequently, to the underlying concrete pipe. The pressure reduction is so great that generally the live load can be neglected. In 1926, Westergaard presented a paper summarizing the results of an extensive study of the effects of loading conditions, subgrade support, and boundary conditions on concrete pavements⁽¹⁾. These results formed the basis by which Westergaard developed a method to calculate the stresses in concrete slabs. Based upon the work of Westergaard and others, the Portland Cement Association, (PCA), developed a method to determine the vertical pressure on buried pipe due to wheel loads applied to concrete pavements⁽²⁾. The PCA method is presented in the American Concrete Pipe Association, ACPA, "Concrete Pipe Handbook"⁽³⁾ and "Concrete Pipe Design Manual"⁽⁴⁾.

Intermediate and thin thicknesses of asphalt or flexible pavements do not reduce the pressure transmitted from a wheel to the pavement subgrade to any significant degree. For these pavements, there is no generally accepted theory for estimating load distribution effects, and, therefore, these pavements should be considered as unsurfaced roadways.

Design of Highway Loads in the US often follows the American Association of State Highway and Transportation Officials, AASHTO, criteria. The AASHTO LRFD Bridge Design Specifications specifies the applicable highway loads and their distribution through the soil.

This Design Data addresses the method of determining the live load pressure transmitted through unsurfaced roadways to circular, elliptical and arch concrete pipe in accordance with the criteria of the AASHTO LRFD Bridge Design Specifications .

INTRODUCTION

To determine the required supporting strength of concrete pipe installed under intermediate and thin thicknesses of asphalt or flexible pavements, or relatively shallow earth cover, it is necessary to evaluate the effect of live loads, such as highway truck loads, in addition to dead loads imposed by the soil and surcharge loads.

LIVE LOADS

If a rigid pavement or a thick flexible pavement designed for heavy duty traffic is provided with a sufficient buffer between the pipe and pavement, then the live load transmitted through the pavement to the buried concrete pipe is usually negligible at any depth. If any culvert or sewer pipe is within the heavy duty traffic highway right-of-way, but not under the pavement structure, then such pipe should be analyzed for the effect of live load transmission from an unsurfaced roadway, because of the possibility of trucks leaving the pavement.

DEAD LOADS

Various methods for analyzing soil dead loads, which have been developed over the years, are presented in the ACPA "Concrete Pipe Technology Handbook"⁽⁷⁾.

SURCHARGE LOADS

A common type of surcharge load is additional soil fill placed after the pipe has been installed for a period of time. If the surcharge load is a building or other surface load, the resultant uniformly distributed load can be converted to an equivalent height of fill, and then evaluated as an additional soil load. When concrete pipe has been installed underground, the soil-structure system will continually show an increase in load capacity. Data on concrete pipe, which have been removed from service and tested, indicate an increase in concrete strength and an increase in load carrying capacity of 10 to 40 percent. Settlement and consolidation will improve the soil structure surrounding the pipe, which also improves load carrying capacity.

LIVE LOADS

The AASHTO design loads commonly used in the past were the HS 20 with a 32,000 pound axle load in the Normal Truck Configuration, and a 24,000 pound axle load in the Alternate Load Configuration (Figure 2). The average pressure intensity caused by a wheel load is calculated by Equation 3.

The AASHTO LRFD design loads are the HS 20 with a 32,000 pound axle load in the Normal Truck Configuration, and a 25,000 pound axle load in the Alternate Load Configuration (Figure 2).

The HS 20, 32,000 pound and the Alternate Truck 25,000 pound design axle are carried on dual wheels (Figure 1). The contact area of the dual wheels with the ground is assumed to be a rectangle (Figure 1), with dimensions presented in Table 1.

Figure 1 AASHTO Wheel Load Surface Contact Area (Foot Print)

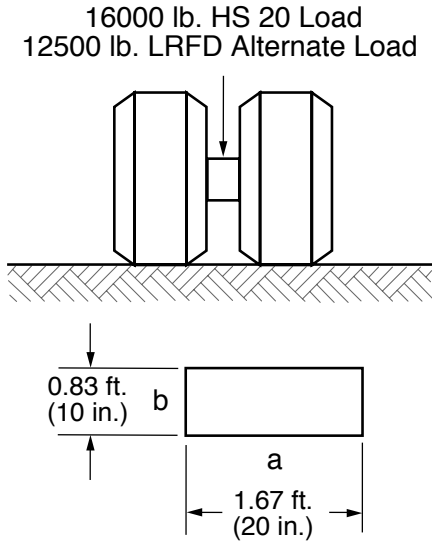

Table 1 LRFD Wheel Surface Contact Area

a(width), ft(in.)	b(length, ft(in.))
1.67(20)	0.83(10)

IMPACT FACTORS

The AASHTO LRFD Standard applies a dynamic load allowance to account for the truck load being non-static. The dynamic load allowance, IM, is determined by Equation 1:

$$IM = \frac{33(1.0 - 0.125H)}{100} \quad [1]$$

where: H = height of earth cover over the top of the pipe, ft.

LOAD DISTRIBUTION

The surface load is assumed to be uniformly spread on any horizontal subsoil plane. The spread load area is developed by increasing the length and width of the wheel contact area for a load configuration as illustrated in Figure 3 for a dual wheel; in Figure 4 for dual wheels of two trucks in passing mode; and in Figure 5 for two dual wheels of two Alternate Load configurations in passing mode. On a horizontal soil plane, the dimensional increases to the wheel contact area are based on height

Figure 2 AASHTO Wheel Loads and Wheel Spacings

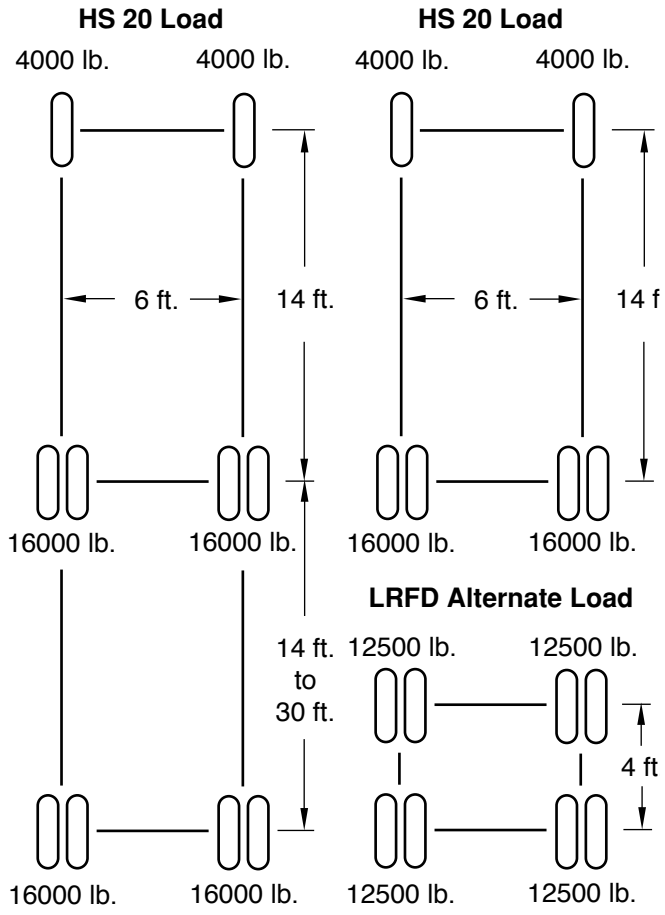

HS 20 & LRFD Alternate Loads

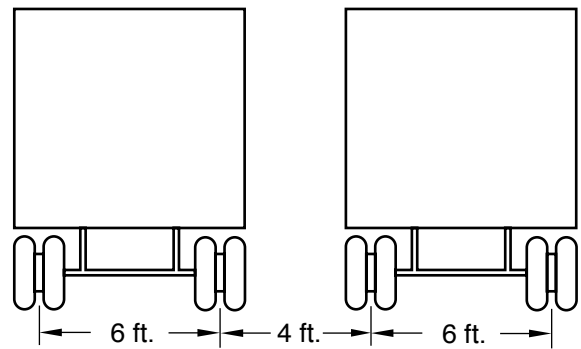

Table 2 LRFD Wheel Contact Area Dimensional Increase Factor

Soil Type	Dimensional Increase Factor
LRFD select granular	1.15H
LRFD any other soil	1.00H

of earth cover over the top of the pipe as presented in Table 2 for two types of soil.

As indicated by Figures 3, 4 and 5, the spread load areas from adjacent wheels will overlap as the height of earth cover over the top of the pipe increases.

Live load will also dissipate through the concrete pipe itself resulting in an effective length that resists this load as demonstrated in Figure 7. The effective supporting length of pipe is:

$$L_e = L + 1.75(3/4R_o) \quad [2]$$

where: R_o = outside vertical rise of pipe, feet

The governing wheel load configuration is thus

Figure 3 Spread Load Area - Single Dual Wheel

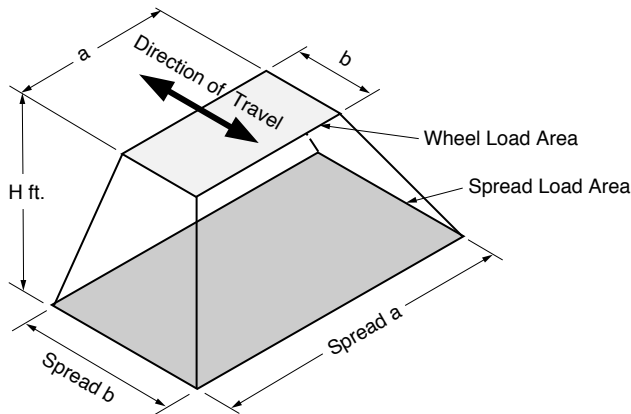

a combination of the overlap in live load pressures distributed through the soil, as well as any instance where the effective lengths from adjacent tires overlap within the pipe itself as shown in Figure 8. These conditions have been summarized in Table 3.

At shallow depths, the maximum pressure will be developed by an HS 20 dual wheel, since at 16,000 pounds it applies a greater load than the 12,500 pound Alternate Load (Figures 2 and 3). At intermediate depths, the maximum pressure will be developed by the wheels of two HS 20 trucks in the passing mode, since at 16,000 pounds each, the two wheels apply a greater load than the 12,500 pounds of an Alternate Load wheel (Figures 2 and 4). At greater depths, the maximum pressure will be developed by wheels of two Alternate Load configuration trucks in the passing mode, since at 12,500 pounds each, the four wheels apply the greatest load (50,000 pounds) (Figures 2 and 5).

DESIGN METHOD

The design method encompasses 4 steps.

1. Obtain the following project data:
Pipe shape, size and wall thickness.
Height of cover over the concrete pipe, and type of earth fill.
LRFD or other criteria.
2. Calculate the average pressure intensity of the wheel loads on the soil plane on the outside top of the pipe.
3. Calculate the total live load acting on the pipe.
4. Calculate the total live load acting on the pipe in pounds per linear foot.

Table 3 LRFD Critical Wheel Loads and Spread Dimensions at the Top of the Pipe

Vehicle Traveling Perpendicular to Pipe					
	H, ft	P, lbs	Spread a, ft	Spread b, ft	Figure
Live Load Distribution of 1.15 x H for Select Granular Fill	$H + 1.15D_o < 2.05$	16,000	$a + 1.15H$	$b + 1.15H$	3
	$2.05 - 1.15D_o < H < 5.5$	32,000	$a + 4 + 1.15H$	$b + 1.15H$	4
	$5.5 < H$	50,000	$a + 4 + 1.15H$	$b + 4 + 1.15H$	5
Live Load Distribution of 1.0 x H for Other Soils	$H + 1.30D_o < 2.30$	16,000	$a + 1.00H$	$b + 1.00H$	3
	$2.30 - 1.30 D_o < H < 6.3$	32,000	$a + 4 + 1.00H$	$b + 1.00H$	4
	$6.3 < H$	50,000	$a + 4 + 1.00H$	$b + 4 + 1.00H$	5
Vehicle Traveling Parallel to Pipe					
Live Load Distribution of 1.15 x H for Select Granular Fill	$H < 2.03$	16,000	$a + 1.15H$	$b + 1.15H$	3
	$2.03 < H < 5.5$	32,000	$a + 4 + 1.15H$	$b + 1.15H$	4
	$5.5 < H$	50,000	$a + 4 + 1.15H$	$b + 4 + 1.15H$	5
Live Load Distribution of 1.0 x H for Other Soils	$H < 2.33$	16,000	$a + 1.00H$	$b + 1.00H$	3
	$2.33 < H < 6.3$	32,000	$a + 4 + 1.00H$	$b + 1.00H$	4
	$6.3 < H$	50,000	$a + 4 + 1.00H$	$b + 4 + 1.00H$	5

Figure 4 Spread Load Area - Two Single Dual Wheels of Trucks in Passing Mode

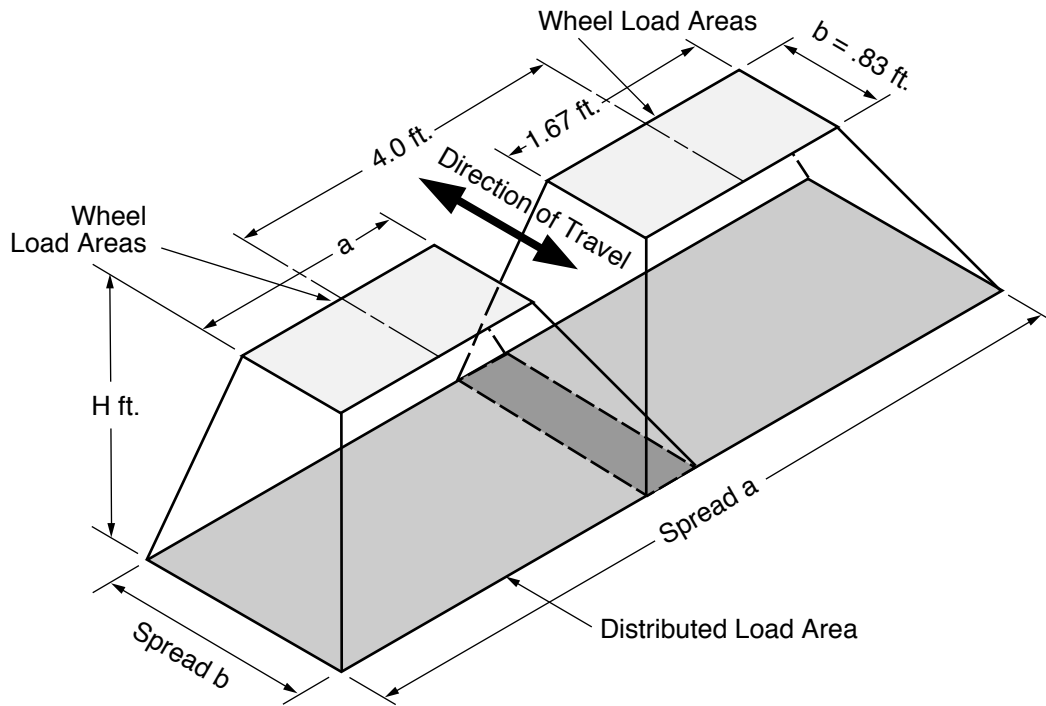
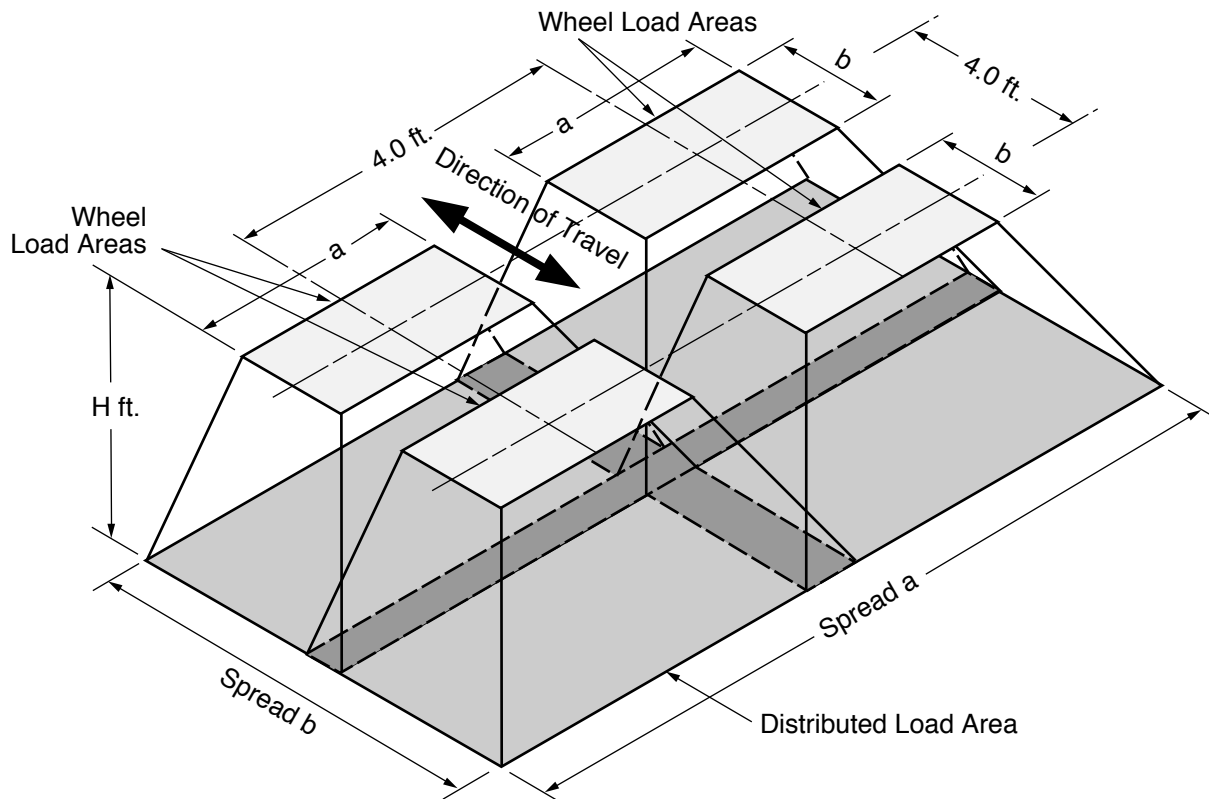

Figure 5 Spread Load Area - Two Single Dual Wheels of Two Alternate Loads in Passing Mode



Project Data

Pipe shape and internal dimensions are shown on the project plans. Complete information on dimensional details are included in ASTM Specification C 14 for nonreinforced circular concrete pipe⁽⁶⁾, C 76 for reinforced concrete circular pipe⁽⁹⁾, C 506 for reinforced concrete arch pipe⁽¹⁰⁾ and C 507 for reinforced concrete elliptical pipe⁽¹¹⁾. Internal size, wall thickness and outside dimensions are presented in Tables 6, 7 and 8 for circular, arch and elliptical pipe respectively.

The minimum earth cover over the concrete pipe can be obtained from the project plans. The type of fill material required under, around and over the concrete pipe will be noted on the project plans or detailed in the contract documents.

A decision regarding whether the AASHTO LRFD or other criteria will be used should be obtained from the project authority.

Average Pressure Intensity

The wheel load average pressure intensity on the subsoil plane at the outside top of the concrete pipe is:

$$w = \frac{P(1 + IM)}{A} \quad [3]$$

- where: w = wheel load average pressure intensity, pounds per square foot
 P = total live wheel load applied at the surface, pounds
 A = spread wheel load area at the outside top of the pipe, square feet
 IM = dynamic load allowance

From the appropriate Table 3, or 4, select the critical wheel load and spread dimensions for the height of earth cover over the outside top of the pipe, H . The spread live load area is equal to Spread a times Spread b . Select the appropriate dynamic load allowance, using Equation 1.

Total Live Load

A designer is concerned with the maximum possible loads, which occur when the distributed load area is centered over the buried pipe. Figure 6 illustrates the dimensions of the spread load area, A , related to whether the truck travel is transverse or parallel to the centerline of the pipe. The total live load acting on the pipe is :

$$W_T = wLS_L \quad [4]$$

- where: W_T = total live load, pounds
 w = wheel load average pressure intensity, pounds per square foot (at the top of the pipe)

Figure 6 Spread Load Area Dimensions vs Direction of Truck

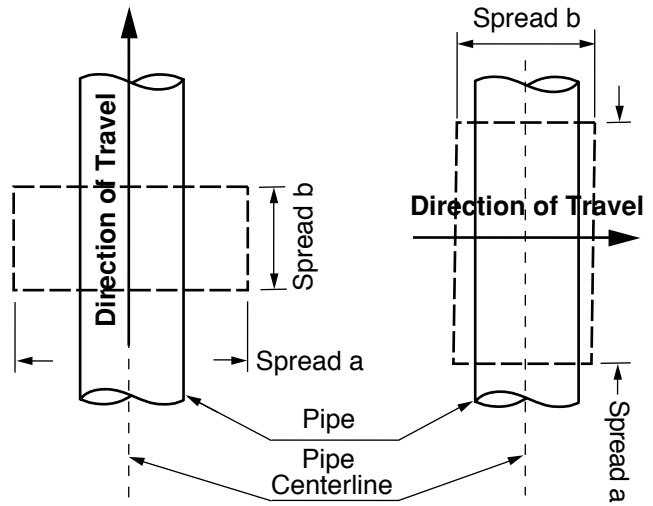

- L = dimension of A parallel to the longitudinal axis of pipe, feet
 For vehicles traveling perpendicular to the pipe, $L = \text{spread } a$
 For vehicles traveling parallel to the pipe, $L = \text{spread } b$
 S_L = outside horizontal span of pipe, D_o , or spread wheel load area, A , transverse to the longitudinal axis of pipe, whichever is less, feet

Total Live Load in Pounds per Linear Foot

The total live load in pounds per linear foot, W_L , is calculated by dividing the Total Live Load, W_T , by the Effective Supporting Length, L_e . (See Figure 7), of the pipe:

$$W_L = \frac{W_T}{L_e} \quad [5]$$

- where: W_L = live load on top of pipe, pounds per linear foot
 L_e = effective supporting length of pipe (see Equation 2 and Figure 7), feet

Figure 7 Effective Supporting Length of Pipe

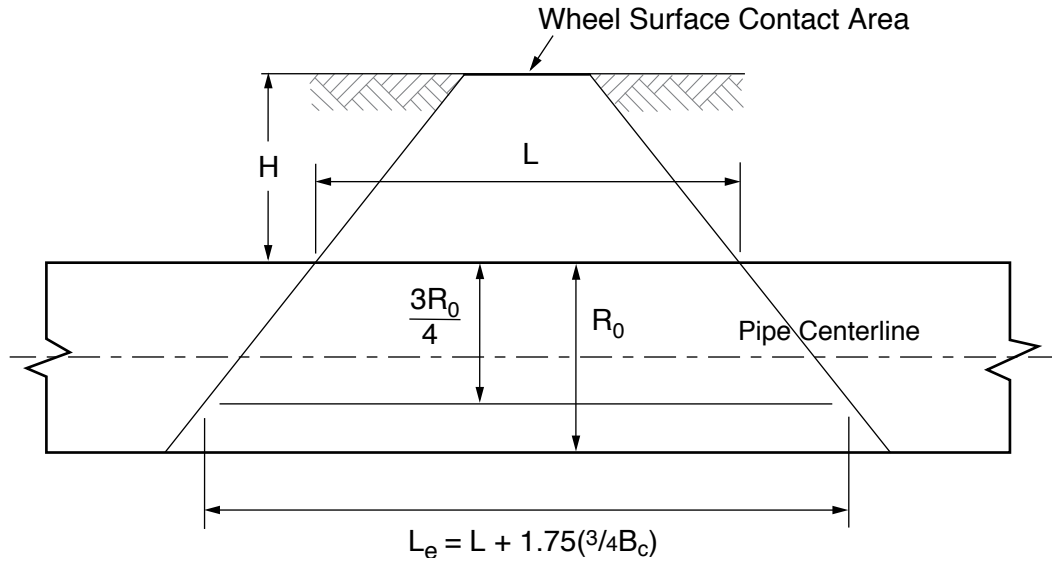
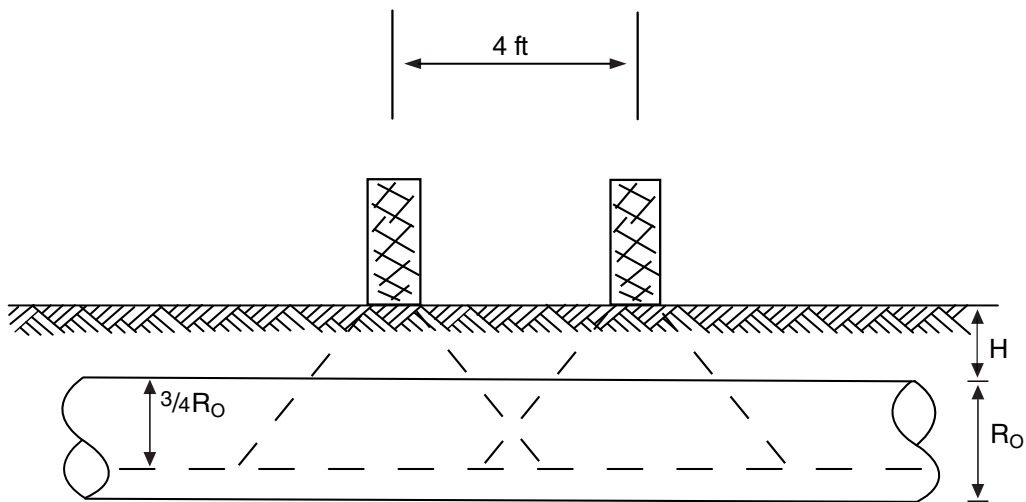

Figure 8 Load Spread Through Soil and Pipe



EXAMPLES

Four Example calculations are presented on the following pages to illustrate the four steps of the Design Method, and the effect of varying the depth of fill and the type of fill. The live loads per linear foot calculated in the four Examples are summarized in Table 4.

Table 4 Summary of LRFD Live Loads Calculated in Examples

Example	D, in	Load	Soil Fill	H, ft	P, lbs	Live Load, plf
1	30	Perpendicular	Select Granular	2	32,000	3,272
2	30	Parallel	Select Granular	2	16,000	2,162
3	30	Perpendicular	Other Soil	2	32,000	3,407
4	30	Perpendicular	Select Granular	6	50,000	855

EXAMPLE 1

Given: A 30-inch diameter, B wall, concrete pipe is to be installed as a storm drain under a flexible pavement and subjected to AASHTO highway loadings that run perpendicular to the pipe. The pipe will be installed in a trench with a minimum of 2 feet of cover over the top of the pipe. The AASHTO LRFD Criteria will be used with Select Granular Soil.

Find: The maximum live load on the pipe in pounds per linear foot.

Solution:

1. Review project data.

A 30-inch diameter, B wall, circular concrete pipe has a wall thickness of 3.5 inches, therefore the outside diameter of the pipe, D_o , and R_o are 3.08 feet. The height of earth cover is 2 feet. Use AASHTO LRFD Criteria with Select Granular Soil Fill.

2. Calculate average pressure intensity of the live load on the plane at the outside top of the pipe.

From Table 3, the critical load, P , is 32,000 pounds from two HS 20 single dual wheels in passing mode, and the Spread Area is:

$$\begin{aligned} A &= (\text{Spread } a)(\text{Spread } b) \\ A &= (1.67 + 4 + 1.15 \times 2)(0.83 + 1.15 \times 2) \\ A &= (7.97)(3.13) \\ A &= 24.9 \text{ square feet} \end{aligned}$$

$$\begin{aligned} \text{From Equation 1:} \\ \text{I.M.} &= 33(1.0 - 0.125H)/100 \\ \text{I.M.} &= .2475 (24.75\%) \end{aligned}$$

$$\begin{aligned} \text{From Equation 3:} \\ w &= P(1 + \text{IM})/A \\ w &= 32,000(1 + .2475)/24.9 \\ w &= 1,603 \text{ lb/ft}^2 \end{aligned}$$

3. Calculate total live load acting on the pipe.

$$\begin{aligned} \text{From Equation 4:} \\ W_T &= wLS_L \end{aligned}$$

Since the truck travels transverse to pipe centerline.

$$\begin{aligned} L &= \text{Spread } a = 7.97 \text{ feet} \\ \text{Spread } b &= 3.13 \text{ feet} \\ D_o &= 3.08 \text{ feet, which is less than Spread } b, \text{ therefore} \\ S_L &= 3.08 \text{ feet} \end{aligned}$$

$$W_T = 1603 \times 7.97 \times 3.08 = 39,300 \text{ pounds}$$

4. Calculate live load on pipe in pounds per linear foot.

$$R_o = 3.08 \text{ feet}$$

$$\begin{aligned} \text{From Equation 2:} \\ L_e &= L + 1.75(3/4R_o) \\ L_e &= 7.97 + 1.75(.75 \times 3.08) = 12.01 \text{ feet} \end{aligned}$$

$$\begin{aligned} W_L &= W_T/L_e \\ W_L &= 39,300/12.01 = 3,272 \text{ pounds per linear foot} \end{aligned}$$

EXAMPLE 2

Given: Same as Example 1, except the live load runs parallel to the pipe.

Find: The maximum live load on the pipe in pounds per linear foot.

Solution:

1. Review project data.

A 30-inch diameter, B wall, circular concrete pipe has a wall thickness of 3.5 inches, therefore D_o and R_o are 3.08 feet. Height of earth cover is 2 feet. Use AASHTO LRFD Criteria with Select Granular Soil Fill.

2. Calculate average pressure intensity of the live load on the plane at the outside top of the pipe.

From Table 3, the critical load, P , is 16,000 pounds from an HS 20 single dual wheel, and the Spread Area is:

$$\begin{aligned} A &= (\text{Spread } a)(\text{Spread } b) \\ A &= (1.67 + 1.15 \times 2)(0.83 + 1.15 \times 2) \\ A &= (3.97)(3.13) \\ A &= 12.4 \text{ square feet} \end{aligned}$$

$$\begin{aligned} \text{From Equation 1:} \\ \text{I.M.} &= 33(1.0 - 0.125H)/100 \\ \text{I.M.} &= .2475(24.75\%) \end{aligned}$$

$$\begin{aligned} \text{From Equation 3:} \\ w &= P(1 + \text{IM})/A \\ w &= 16,000(1 + .2475)/12.4 \\ w &= 1,610 \text{ lb/ft}^2 \end{aligned}$$

3. Calculate total live load acting on the pipe.

$$\begin{aligned} \text{From Equation 4:} \\ W_T &= wLS_L \end{aligned}$$

Since the truck travels parallel to pipe centerline.

Spread a = 3.97 feet
 L = Spread b = 3.13 feet
 $B_c = 3.08$ feet, which is less than Spread a, therefore
 $S_L = 3.08$ feet

$$W_T = (1603)3.08 \times 3.13 = 15,500 \text{ pounds}$$

4. Calculate live load on pipe in pounds per linear foot.

$$R_o = 3.08 \text{ feet}$$

$$L_e = L + 1.75(3/4R_o)$$

$$L_e = 3.13 + 1.75(.75 \times 3.08) = 7.17 \text{ feet}$$

$$W_L = W_T/L_e$$

$$W_L = 15,500/7.17 = 2,162 \text{ pounds per linear foot}$$

EXAMPLE 3

Given: Same as Example 1, except use AASHTO LRFD Criteria with Other Soils Fill.

Find: The maximum live load on the pipe in pounds per linear foot.

Solution:

1. Review project data.

A wall B 30-inch diameter circular concrete pipe has a wall thickness of 3.5 inches, therefore the outside diameter of the pipe, D_o , and R_o are 3.08 feet. Height of earth cover is 2 feet. Use AASHTO LRFD Criteria with Other Soils Fill.

2. Calculate average pressure intensity on the plane at the top of the pipe.

From Table 3, the critical load, P, is 32,000 pounds from two HS 20 single dual wheels in passing mode, and the Spread Area is:

$$A = (\text{Spread } a)(\text{Spread } b)$$

$$A = (1.67 + 4 + 1.00 \times 2)(0.83 + 1.00 \times 2)$$

$$A = (7.67)(2.83)$$

$$A = 21.71 \text{ square feet}$$

From Equation 1:

$$I.M. = 33(1.0 - 0.125H)/100$$

$$I.M. = .2475$$

From Equation 3:

$$w = P(I + IM)/A$$

$$w = 32,000(1 + .2475)/21.71$$

$$w = 1,839 \text{ lb/ft}^2$$

3. Calculate total live load acting on the pipe.

From Equation 4:

$$W_T = wLS_L$$

Since the truck travels transverse to pipe centerline.

$$L = \text{Spread } a = 7.67 \text{ feet}$$

$$\text{Spread } b = 2.83 \text{ feet}$$

$D_o = 3.08$ feet, which is greater than Spread b, therefore

$$S_L = 2.83 \text{ feet}$$

$$W_T = 1,839 \times 7.67 \times 2.83 = 39,900 \text{ pounds}$$

4. Calculate live load on pipe in pounds per linear foot.

$$R_o = 3.08 \text{ feet}$$

From Equation 2:

$$L_e = L + 1.75(3/4R_o)$$

$$L_e = 7.67 + 1.75(.75 \times 3.08) = 11.71 \text{ feet}$$

$$W_L = W_T/L_e$$

$$W_L = 39,900/11.71 = 3,407 \text{ pounds per linear foot}$$

EXAMPLE 4

Given: Same as Example 1, except minimum depth of fill is 6 feet.

Find: The maximum live load on the pipe in pounds per linear foot.

Solution:

1. Review project data.

A wall B 30-inch diameter circular concrete pipe has a wall thickness of 3.5 inches, therefore the outside diameter of the pipe, D_o , and R_o are 3.08 feet. Height of earth cover is 6 feet. Use AASHTO LRFD Criteria with Select Granular Soil Fill.

2. Calculate average pressure intensity at the outside top of the pipe.

From Table 3, the critical load, P, is 50,000 pounds from two single dual wheels of two Alternate Load Configurations in the passing mode, and the Spread Area is:

$$A = (\text{Spread } a)(\text{Spread } b)$$

$$A = (1.67 + 4 + 1.15 \times 6)(0.83 + 4 + 1.15 \times 6)$$

$A = (12.57)(11.73)$
 $A = 147.45$ square feet
 From Equation 1:
 $I.M. = 33(1 - 0.125H)/100$
 $I.M. = 0.0825$

From Equation 3:
 $w = P(1 + I.M.) / A = 50,000(1 + 0.0825) / 147.45$
 $w = 367$ lb/ft²

3. Calculate total live load acting on the pipe.

$$W_T = wLS_L$$

Since the truck travels transverse to pipe centerline.

$L =$ Spread $a = 12.57$ feet
 Spread $b = 11.73$ feet
 $D_o = 3.08$ feet, which is less than Spread b , therefore
 $S_L = 3.08$ feet

$$W_T = 367 \times 12.57 \times 3.08 = 14,200 \text{ pounds}$$

4. Calculate live load on pipe in pounds per linear foot.

$$R_o = 3.08 \text{ feet}$$

From Equation 2:

$$L_e = L + 1.75(3/4R_o)$$

$$L_e = 12.57 + 1.75(0.75 \times 3.08) = 16.6 \text{ feet}$$

$$W_L = W_T / L_e$$

$$W_L = 14,200 / 16.6 = 855 \text{ pounds per linear foot}$$

Table 6 Dimensions of Circular Concrete Pipe			
Internal Diameter, inches	Wall A	Wall B	Wall C
	Minimum Wall Thickness, inches	Minimum Wall Thickness, inches	Minimum Wall Thickness, inches
12	1-3/4	2	-
15	1-7/8	2-1/4	-
18	2	2-1/2	-
21	2-1/4	2-3/4	-
24	2-1/2	3	3-3/4
27	2-5/8	3-1/4	4
30	2-3/4	3-1/2	4-1/4
33	2-7/8	3-3/4	4-1/2
36	3	4	4-3/4
42	3-1/2	4-1/2	5-1/4
48	4	5	5-3/4
54	4-1/2	5-1/2	6-1/4
60	5	6	6-3/4
66	5-1/2	6-1/2	7-1/4
72	6	7	7-3/4
78	6-1/2	7-1/2	8-1/4
84	7	8	8-3/4
90	7-1/2	8-1/2	9-1/4
96	8	9	9-3/4
102	8-1/2	9-1/2	10-1/4
108	9	10	10-3/4
114	9-1/2	10-1/2	11-1/4
120	10	11	11-3/4
126	10-1/2	11-1/2	12-1/4
132	11	12	12-3/4
138	11-1/2	12-1/2	13-1/4
144	12	13	13-3/4
150	12-1/2	13-1/2	14-1/4
156	13	14	14-3/4
162	13-1/2	14-1/2	15-1/4
168	14	15	15-3/4
174	14-1/2	15-1/2	16-1/4
180	15	16	16-3/4

Table 7 Dimensions of Arch Concrete Pipe			
Equivalent Round Size, inches	Minimum Rise, inches	Minimum Span, inches	Minimum Wall Thickness, inches
	15	11	18
18	13-1/2	22	2-1/2
21	15-1/2	26	2-3/4
24	18	28-1/2	3
30	22-1/2	36-1/4	3-1/2
36	26-5/8	43-3/4	4
42	3-15/16	5-1/8	4-1/2
48	36	58-1/2	5
54	40	65	5-1/2
60	45	73	6
72	54	88	7
84	62	102	8
90	72	115	8-1/2
96	77-1/4	122	9
108	87-1/8	138	10
120	96-7/8	154	11
132	106-1/2	168-3/4	10

Table 7 Dimensions of Elliptical Concrete Pipe			
Equivalent Round Size, inches	Minor Axis, inches	Major Axis, inches	Minimum Wall Thickness, inches
18	14	23	2-3/4
24	19	30	3-1/4
27	22	34	3-1/2
30	24	38	3-1/4
33	27	42	3-3/4
36	29	45	4-1/2
39	32	49	4-3/4
42	34	53	5
48	38	60	5-1/2
54	43	68	6
60	48	76	6-1/2
66	53	83	7
72	58	91	7-1/2
78	63	98	8
84	68	106	8-1/2
90	72	113	9
96	77	121	9-1/2
102	82	128	9-3/4
108	87	136	10
114	92	143	10-1/2
120	97	151	11
132	106	166	12
144	116	180	13

References

1. Westergaard, H.M., "Stresses in Concrete Pavements Computed by Theoretical Analysis," Public Roads, April, 1926.
2. "Vertical Pressure on Culverts Under Wheel Loads on Concrete Pavement Slabs," Portland Cement Association, 1944.
3. "*Concrete Pipe Handbook*", American Concrete Pipe Association, 1998.
4. "*Concrete Pipe Design Manual*", American Concrete Pipe Association, 2000.
5. "*Standard Specifications for Highway Bridges*", American Association for State Highway and Transportation Officials.
6. "*LRFD Bridge Design Specifications*", American Association for State Highway and Transportation Officials.
7. "*Concrete Pipe Technology Handbook*", American Concrete Pipe Association, 1993.
8. ASTM Standard C 14, "Specification for Concrete Sewer, Storm Drain, and Culvert Pipe," American Society for Testing and Materials.
9. ASTM Standard C 76, "Specification for Reinforced Concrete Culvert, Storm Drain, and Sewer Pipe," American Society for Testing and Materials.
10. ASTM Standard C 506, "Specification for Reinforced Concrete Arch Culvert, Storm Drain, and Sewer Pipe," American Society for Testing and Materials.
11. ASTM Standard C 507, "Specification for Reinforced Concrete Elliptical Culvert, Storm Drain, and Sewer Pipe," American Society for Testing and Materials.