

Railway Loads on Concrete Pipe

FOREWORD

Historically, the American Railway Engineering Association, AREA, has published criteria for design of railways, including the method for designing and installing concrete pipe within railway right-of-way. Railway design criteria is now developed and published by the American Railway Engineering and Maintenance-of-Way Association (AREMA) in the "AREMA Manual for Railway Engineering"¹. Concrete pipe material, design, and installation is covered in Chapter 8, Part 10, "Reinforced Concrete Culvert Pipe" of the AREMA Manual¹. Each railway company may have their own modifications to the AREMA criteria. Pipe criteria should be thoroughly discussed with the specifier prior to designing the pipe for a project.

Design Data 3 provides a simple means of analyzing railway live and dead loads on concrete pipe. The loading information is applicable to circular, arch, and elliptical pipe shapes. AREMA, Part 10, specifies the indirect design method in which the installation is dependent on a combination of specific pipe strengths and details of the soil envelope supporting the pipe. More recently, the direct design method has been developed to provide a more rational means of analyzing pipe strength and specifying installation details. The method analyzes the composite strength of the soil-pipe structure used in the installation. Research by the American Concrete Pipe Association (ACPA) has provided a series of improved Standard Installation details that can be used with either the direct or the indirect design method⁹.

INTRODUCTION

To determine the required design strength of concrete pipe installed within railway right-of-way, it is necessary to evaluate the effect of live loads imposed by a train, dead loads imposed by the soil, and surcharge loads imposed by structures such as bridge piers or abutments, to the top of the pipe.

METHODS OF ANALYSIS

Part 10 of Chapter 8 of the AREMA Manual¹ states that satisfactory design methods utilizing more exact design procedures for dead loads are presented in the ACPA publications "Concrete Pipe Design Manual"⁹ and "Concrete Pipe Handbook"¹⁰. These ACPA publications

now include the Standard Installations.

The ACPA's research resulted in a soil structure design method for buried concrete pipe, "SIDD," Standard Installation Direct Design. The SIDD Program was subsequently incorporated into the Federal Highway Administration's Pipe Culvert Analysis Reinforcing (PIPECAR) program. The program calculates concrete pipe designs for railway, highway, and airport live loads, dead loads and surcharge loads. Design Data 40, "Standard Installation and Bedding Factors for the Indirect Design Method" may be referenced for manual calculations.

LIVE LOADS

The railway supporting ties and rails are considered the track structure, which distributes train loads to the soil or bridges. Live loads are assumed to be applied, by the ties, uniformly to the surface of the ballast and then distributed through the embankment to the pipe, see Figure 1. As a design track loading, AREMA recom-

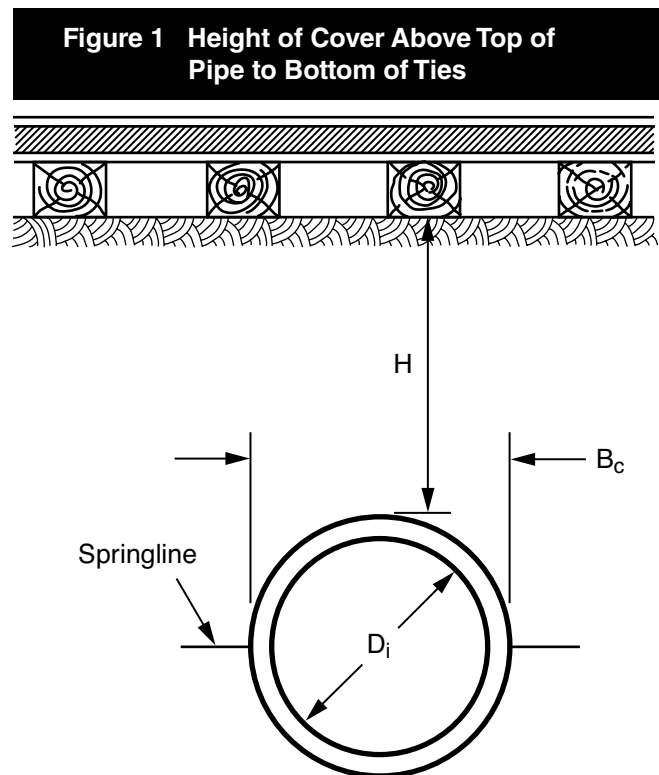
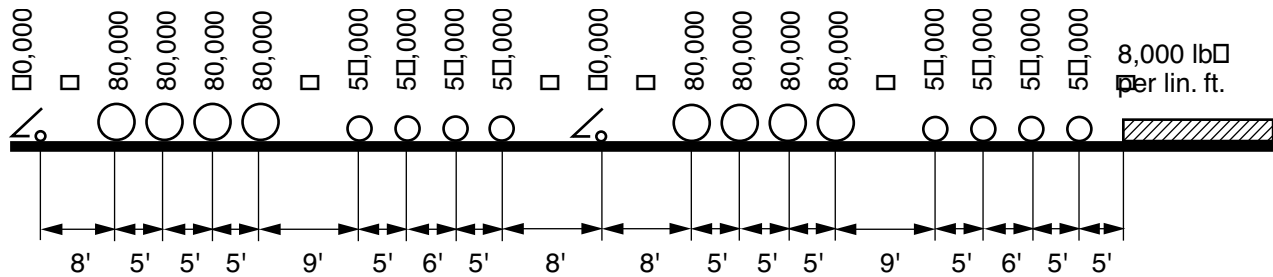

Figure 1 Height of Cover Above Top of Pipe to Bottom of Ties

Figure 2 Cooper E 80 Wheel Loads and Axle Spacing



mends a Cooper E 80 loading, which has axle loadings and spacings as shown in Figure 2, and a linearly variable impact factor that is 40% at the bottom of the ties and zero at 10 feet of cover below the ties. Based on a uniform load distribution at the bottom of the ties and through the soil mass, the design track unit load, WL, in pounds per square foot, is determined from the AREMA graph presented in Figure 3. To obtain the live load transmitted

to the pipe in pounds per linear foot, it is necessary to multiply the unit load, WL, from Figure 3, by the outside span, B_c , of the pipe in feet. The pipe size or equivalent pipe size and outside diameter or horizontal span is presented in Table 1 for circular, arch and elliptical pipe respectively.

Loadings on a pipe within a casing pipe shall be taken as the full dead load, plus live load, plus impact load without consideration of the presence of the casing pipe, unless the casing pipe is fully protected from corrosion.

Culvert or sewer pipe within the railway right-of-way, but not under the track structure, should be analyzed for the effect of live loads because of the possibility of train derailment.

Figure 3 Loads on Concrete Pipe Installed Under Railways

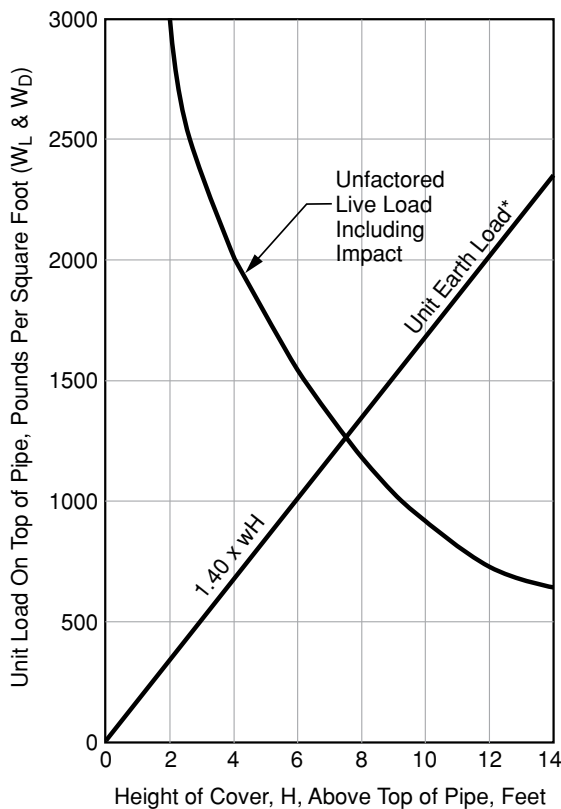

*Fill for embankment installations
 $DL/B_c = 1.40wH$ with $w = 120 \text{ lb/ft}^3$
 1.40 = Vertical Arching Factor

EARTH LOAD

The unit fill load, in pounds per square foot (psf), for embankment installations is given by the straight line in Figure 3. The fill load is based on a Type 2 Standard Installation, as defined in ASTM Standard C 1479, "Standard Practice for Installation of Reinforced Concrete Sewer, Storm Drain, and Culvert Pipe." A detailed explanation of the Standard Installations can also be found in ACPA's Design Data 40, "Standard Installations and Bedding Factors for the Indirect Design Method." A Type 2 Installation requires 90% compaction of a granular material up to the springline of the pipe. Most railroad industries maintain a well compacted envelope of at least 90% standard proctor around and above the pipe to support the track. The soil prism load directly above the pipe is increased by a dimensionless vertical arching factor of 1.40 to account for the additional portion of the embankment supported by the pipe. The unit fill in pounds per square foot is read directly from Figure 3. To convert the unit load WD to pounds per linear foot, multiply by the outside horizontal span, B_c , of the pipe in feet.

SURCHARGE LOADS

Any uniform static surface surcharge load should be converted to additional height of fill to determine the total dead load on the pipe. The ACPA "Concrete Pipe

Design Manual”⁹, the ACPA “Concrete Pipe Handbook”¹⁰ and the ACPA’s “PIPECAR”¹¹ computer program design procedures incorporate surcharge loads by converting them to additional heights of fill.

EXAMPLE 1

An Example follows to illustrate the determination of the railway live load for a concrete pipe installation.

GIVEN

A 48-inch diameter, B wall, circular pipe is to be installed under a railway with 4 feet of cover between the bottom of the ties and the top of the pipe.

FIND

The live load and dead load, in pounds per linear foot, on top of the pipe.

SOLUTION

Enter Figure 3 at H = 4.0 feet on the horizontal scale, “Height of Cover, H, Above Top of Pipe”, and project a vertical line to the “Live Load Including Impact” curve. From the curve project a horizontal line left to the vertical scale, “Unit Load on Top of Pipe”, read 2,000 pounds per square foot.

To obtain the live load in pounds per linear foot of pipe, multiply the Unit Live Load, WL, by the outside horizontal span, Bc, of the pipe. From Table 1A, Bc = 4.83 ft. and the live load is:

$$LL = 2,000 \times 4.83 = 9,660 \text{ pounds per linear foot}$$

To calculate the earth load, DL, use Figure 3 and the same procedure as used for finding the live load. Multiply the unit dead load, WD, by the horizontal space, Bc, of the pipe. The dead load is:

$$DL = 700 \times 4.83 = 3,400 \text{ pounds per linear foot}$$

EXAMPLE 2

An example follows to illustrate the determination of the railway live load for a concrete pipe installation

Given

A 15-inch circular pipe is to be installed under a railroad in a positive projecting embankment condition, in ordinary soil. The pipe will be covered with 3 ft of 120 lb/ft³ overfill (measured from top of pipe to bottom of ties.)

Find

The required pipe strength in terms of 0.01 in. crack D-Load.

Solution

The unit dead load on top of the pipe can be determined from Figure 3. Where the height of cover equal to 3 ft intersects the Unit Earth Load line, the dead load is 500 lb/ft².

$$W_D = 500 \text{ lb/ft}^2$$

$$\begin{aligned} W_E &= W_D D_o \\ &= 500 \times 1.625 \\ &= 813 \text{ lb/ft} \end{aligned}$$

From Figure 3, for a 15 in. diameter pipe with H= 3 ft and a COOPER E80 design load, the unit live load is 2,350 lb/ft².

$$\begin{aligned} W_{LL} &= W_L D_o \\ &= 2,350 \times 1.625 \\ &= 3,819 \text{ lb/ft} \end{aligned}$$

Since the pipe is under shallow cover and railroad loading, a Type 1 installation will be used. Per the given information, the installation behaves as a positive projecting embankment. According to the ACPA manual, an earth load and live load bedding factor of 4.3 and 2.2 is obtained, respectively.

A factor of safety of 1.0 based on the 0.01 in. crack will be applied.

$$D\text{-load} = \left[\frac{W_E}{B_{fe}} + \frac{W_{LL}}{B_{fLL}} \right] \frac{F.S.}{D}$$

$$\begin{aligned} D\text{-load} &= \left[\frac{813}{4.3} + \frac{3,819}{2.2} \right] \frac{1}{1.25} \\ &= 1,540 \text{ lb/ft/ft} \end{aligned}$$

A pipe that can withstand a minimum three-edge bearing test load for a 0.01 in. crack of 1,540 lb/ft/ft of internal diameter or a Class IV pipe would be required.

Size or Equivalent Round Size Inches	Circular Pipe			Arch Pipe Span	Elliptical Pipe Span ASTM C507	
	B Wall RCP ASTM C76	C Wall RCP ASTM C76	Non-Reinforced ASTM C14	ASTM C506	Vertical	Horizontal
					Elliptical	Elliptical
4	-	-	0.46	-	-	-
6	-	-	0.65	-	-	-
8	-	-	0.85	-	-	-
10	-	-	1.04	-	-	-
12	1.33	-	1.29	-	-	-
15	1.63	-	1.56	1.88	-	-
18	1.92	-	1.88	2.25	1.63	2.38
21	2.21	-	2.21	2.63	-	-
24	2.50	2.63	2.56	2.88	2.08	3.00
27	2.79	2.92	2.88	-	2.38	3.38
30	3.08	3.21	3.21	3.60	2.58	3.75
33	3.38	3.50	3.50	-	2.88	4.13
36	3.67	3.88	3.79	4.31	3.17	4.50
39	-	-	-	-	3.46	4.88
42	4.25	4.38	-	5.01	3.67	5.25
48	4.83	4.96	-	5.71	4.08	5.92
54	5.42	5.54	-	6.33	4.58	6.67
60	6.00	6.13	-	7.08	5.08	7.42
66	6.58	6.71	-	-	5.58	8.08
72	7.17	7.29	-	8.50	6.08	8.83
78	7.75	7.88	-	-	-	-
84	8.33	8.46	-	10.33	-	-
90	8.92	9.04	-	11.00	-	-
96	9.50	9.63	-	11.67	-	-
102	10.08	10.21	-	-	-	-
108	10.67	10.79	-	13.17	-	-
114	11.25	11.38	-	-	-	-
120	11.83	11.96	-	14.67	-	-
126	12.42	12.54	-	-	-	-
132	13.00	13.13	-	15.73	-	-
138	13.58	13.71	-	-	-	-
144	14.17	14.29	-	-	-	-

REFERENCES

1. "Part 10 Reinforced Concrete Culvert Pipe, Chapter 8, Concrete Structures and Foundations, AREMA Manual of Railway Engineering", American Railway Engineering and Maintenance-of-Way Association, 1999.
2. "ASTM C-14-Standard Specification for Concrete Sewer, Storm Drain and Culvert Pipe", American Society for Testing and Materials.
3. "ASTM C 76-Standard Specification for Reinforced Concrete Culvert, Storm Drain, and Sewer Pipe", American Society for Testing and Materials.
4. "ASTM C 506-Standard Specification for Reinforced Concrete Arch Culvert, Storm Drain, and Sewer Pipe", American Society for Testing and Materials.
5. "ASTM C 507-Standard Specification for Reinforced Concrete Elliptical Culvert, Storm Drain, and Sewer Pipe", American Society for Testing and Materials.
6. "ASTM C 655-Standard Specification for Reinforced Concrete D-Load Culvert, Storm Drain, and Sewer Pipe", American Society for Testing and Materials.
7. "ASTM C 985-Standard Specification for Nonreinforced Concrete Specified Strength Culvert, Storm Drain, and Sewer Pipe", American Society for Testing and Materials.
8. "ASTM C 1417-Standard Specification for Manufacture of Reinforced Concrete Sewer, Storm Drain, and Culvert Pipe for Direct Design", American Society for Testing and Materials.
9. "Concrete Pipe Design Manual", American Concrete Pipe Association, 2000.
10. "Concrete Pipe Handbook", American Concrete Pipe Association, 1998.
11. "PIPECAR Computer Program", American Concrete Pipe Association, 2001.